



AIR Control Display 57

Installation Manual

Document: MAN0010A0002
Version: 3.0
Date: 2021/06/30

Please read this manual carefully before installing the device.

Observe limitations and safety instructions.

This manual is an essential portion of the device and must be kept in a safe place.

Articles Covered

This manual covers the following articles:

- ACD-57 “AIR Control Display 57”

Revision History

<i>Rev.</i>	<i>Date</i>	<i>Status</i>	<i>Author</i>	<i>Changes</i>	<i>Approved</i>
1.0	2017/04/06	Release	M. Förderer	Initial release	J. Garrecht
1.1	2017/06/19	Release	H. Hoeth	Fixed CAN node ID range	J. Garrecht
1.2	2017/06/26	Release	H. Hoeth	Fixed lists of deviations and limitations Specify wire gauge for installation List non-ETSO functions DO-160 environmental conditions DO-178C and DO-254 DAL	J. Garrecht
1.3	2017/07/19	Release	H. Hoeth	Part numbers of compatible devices	J. Garrecht
1.4	2017/08/16	Release	H. Hoeth	Clarify configuration options for connected COM systems Added part numbers for compatible KRT-2 COM devices Typos and grammar fixes	J. Garrecht
1.5	2017/10/10	Release	H. Hoeth	Fixed cabling diagram image orientation	J. Garrecht
1.6	2017/11/16	Release	H. Hoeth	Fixed typos in cabling diagrams and example configurations	J. Garrecht
1.7	2017/11/30	Release	H. Hoeth	Added VT-01 Ultracompact to the list of compatible devices	J. Garrecht
1.8	2018/01/20	–	H. Hoeth	Updated manual for ACD-57-SW-(0.41): Added serial control interface specification	
1.9	2018/03/09	–	H. Hoeth	Updated config menu structure Fixed typo regarding CAN bus termination	
2.0	2018/03/29	Release	H. Hoeth	Updated manual for ACD-57-SW-(0.42): Fixed error in serial control interface specification Add VT-01 software versions to the list of compatible devices	J. Garrecht
2.1	2018/07/12	Release	H. Hoeth	Added trouble shooting chapter Clarify “channel spacing” setting	J. Garrecht

<i>Rev.</i>	<i>Date</i>	<i>Status</i>	<i>Author</i>	<i>Changes</i>	<i>Approved</i>
2.2	2019/01/30	-	T. Fetzer	Fixed error in serial control interface specification: Changed output format of PAAVS,ALT altitude values	
3.0	2021/06/30	Release	H. Hoeth	Updated manual for ACD-57-SW-(0.44): Added AIR COM related information Added TRIG TT2x and TY9x to the list of compatible devices	J. Garrecht

Product Support

If you have questions, our product support team will be happy to help you. Contact us via support@air-avionics.com or by phone. Please find details about our hotlines and availability online at <https://www.air-avionics.com>

General Description · 1

Introduction · 1

Equipment Description · 1

System Capabilities · 2

Technical Specifications · 2

Regulatory Compliance · 4

Liability · 6

Unpacking and Inspecting Equipment · 6

Installation Materials · 7

System Interconnects and Interfaces · 9

Pin Function List · 10

Data Interfaces · 10

Power and Lighting Functions · 13

Altitude Functions · 14

Installation Overview · 16

General Handling Recommendations · 16

Workmanship · 16

Cabling and Wiring Considerations · 17

Pressure Tubing Considerations · 18

ACD-57 Mounting Considerations · 18

COM and Transponder Compatibility Considerations · 18

Air Circulation and Cooling · 21

Compass Safe Distance · 21

Installation Procedures · 22

Equipment Mounting · 22

Wiring · 22

Interconnect Installation · 22

Post Installation Configuration, Checkout, and Documentation · 23

Post Installation Checkout · 24

Wiring Checks · 24

Connector Engagement Checks · 24

System Configuration · 25

Configuration Operations · 25

License Management · 26

Device Configuration · 27

Altimeter Configuration · 34

ACD-57 COM Control Configuration · 36

Connected COM System Configuration · 40

ACD-57 XPDR Control Configuration · 41

Connected XPDR System Configuration · 43

Ground Checks · 47

Interface Checkout · 47

Serial Control Interface Check · 47

COM Check · 47

XPDR Check · 47

Altimeter Check · 48

Lighting and Controls Check · 48

Version / Revision Check · 49

License Check · 49

Failure Message Check · 49

Configuration and Checkout Documentation · 50

Configuration Documentation · 50

Checkout Documentation · 50

License Documentation · 50

Maintenance · 51

Software and Database Loading · 51

Cleaning · 53

Troubleshooting · 54

My unit says “No Info To Show” · 54

Transponder shows error “0002000 CONNECTION” when switching to ALT mode · 54

Bibliography · 55

Assembly and Installation Drawings · 56

Configuration Menu Diagram · 57

Cabling and Configuration Examples · 61

Display Only (Altimeter) · 61

ACD-57 and AIR COM VHF Transceiver · 63

Dual ACD-57 and AIR COM VHF Transceiver · 66

ACD-57 and Becker 620X or TRIG TY91/92 VHF Transceiver · 69

Dual ACD-57 and Becker 620X / TRIG TY91/92: Transceiver · 72

ACD-57 and Dittel/TQ KRT-2 VHF Transceiver · 76

Dual ACD-57 and Dittel/TQ KRT-2 VHF Transceiver · 78

ACD-57 and VT-01 Transponder · 81

Dual ACD-57 and VT-01 Transponder · 83

ACD-57, AIR COM, and VT-01 Transponder · 86

Dual ACD-57, AIR COM, and VT-01 Transponder · 88

ACD-57, Becker/TRIG radio, and VT-01 Transponder · 91

Dual ACD-57, Becker/TRIG radio, and VT-01 Transponder · 94

ACD-57, Dittel KRT2, and VT-01 Transponder · 98

Dual ACD-57, Dittel KRT2, and VT-01 Transponder · 100

Wiring Diagrams · 103

Generic Wiring Diagram · 103

COM Wiring Diagrams · 104

Transponder Wiring Diagrams · 108

COM and Transponder Wiring Diagrams · 109

Serial Control Interface · 110

RS-232 Interface · 110

Message Structure · 110

Multiple Device Support · 110

Configuration Sentences · 110

Command Sentences · 113

Status Sentences · 113

Error Sentences · 115

Checkout Log · 116

Installation · 116

Ground Checks · 116

Interference Checks · 116

Documentation · 116

Configuration Log · 117

Device · 117

Altimeter · 118

COM Control Configuration · 118

COM System Configuration · 118

XPDR Control Configuration · 118

XPDR System Configuration · 118

License Log · 119

Installed Function Licenses · 119

1.1 Introduction

This manual is intended to provide mechanical and electrical information for use in the planning and design of an installation of the Air Control Display 57 (ACD-57) into an aircraft. This manual is not a substitute for an approved airframe-specific maintenance manual, installation design drawing, or complete installation data package. Attempting to install equipment by reference to this manual alone and without first planning or designing an installation specific to your aircraft may compromise your safety and is not recommended. The content of this manual assumes use by competent and qualified avionics engineering personnel and/or avionics installation specialists using standard aviation maintenance practices in accordance with relevant accepted practices. This manual is not intended for use by individuals who do not possess the competencies and abilities set forth above. Refer to section "Limitations" for additional information and other considerations.

All screen shots used in this document are current at the time of publication. Screen shots are intended to provide visual reference only. All information depicted in screen shots, including software file names, versions, and part numbers, is subject to change and may not be up to date.

1.2 Equipment Description

<i>Model</i>	<i>Part number</i>	<i>Description</i>
AIR Control Display 57	ACD-57-()	Multi Function Display for 57mm standard panel cutout

ACD-57 marks the heart of a new avionics platform with advanced component redundancy. The small outline and multifunctional software of the device allow for better system integration in space constrained environments. The pilot-centered user interface aims at reducing crew workload, increasing crew efficiency and improving flight safety.

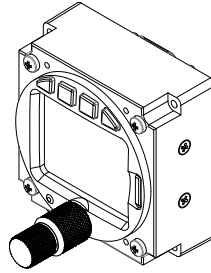

Figure 1.1.: Isometric view of AIR Control Display 57

1.3 System Capabilities

ACD-57 is a small multi-function control display intended for controlling Mode-S Transponders (ATC radar beacon system, ATCRBS) and Aircraft Radios (Airborne VHF Transceivers). Furthermore the system is capable of determining and displaying a precise pressure altitude. The system is connected to transponder and radio devices using standardized interfaces.

1.4 Technical Specifications

1.4.1 Characteristics

<i>Parameter</i>	<i>Data</i>	<i>Unit</i>
Mechanical		
Dimensions	61.5x61.5x26.3	mm
Mounting	Panel cut out, 57	mm
Mass	0.143	kg
Depth behind panel without connectors	27	mm
Depth in front of panel	29	mm
Electrical		
Voltage (nom.)	13.8	V DC
Voltage (operational)	9 to 32	V DC
Low voltage shutdown	8	V DC
Current (nom.)	0.07	A
Optical		
Brightness	0.2 – 1350	cd/m ²
Viewing Angle	45	°
Contrast (darkness)	28:1	
Contrast (max. ambient)	6:1	
LCD Viewing Area	40.5 x 32.2	mm
LCD Viewing Envelope	45 / 45 / 45 / 45	°

Please find a dimensional drawing in appendix B

1.4.2 Environmental Specifications

The ETSO approval is only valid if the device is installed within an environment matching the qualification environment. The ACD-57 has been tested in accordance with RTCA DO-160D Chg. 3:

<i>Description</i>	<i>Section</i>	<i>Category</i>	<i>Conditions</i>
Temperature / Altitude D1	4.0	D1	
Low Ground Survival Temperature	4.5.1	D1	-55°C
Low Operating Temperature	4.5.1	D1	-20°C
High Ground Survival Temperature	4.5.2	D1	+85°C
High short Time Operating Temperature	4.5.2	D1	+70°C
High Operating Temperature	4.5.3	D1	+55°C
In Flight Loss of Cooling	4.5.4	Z	No auxiliary cooling required
Altitude	4.6.1	D1	50,000 ft (alticoder / altimeter limited to 40,000ft)
Temperature Variation	5.0	B	5°C / minute
Humidity	6.0	A	
Shock	7.0	B	6 G operational, 20 G crash safety
Vibration	8.0	U	Vibration curve F/F1
		S	Vibration curve M
Explosion Proofness	9.0	X	not tested
Water Proofness	10.0	X	not tested
Fluids Susceptibilities	11.0	X	not tested
Sand and Dust	12.0	X	not tested
Fungus Resistance	13.0	X	not tested
Salt Spray	14.0	X	not tested
Magnetic Effect	15.0	Z	Less than 0.3m
Power Input (DC)	16.0	B	
Voltage Spike Conducted	17.0	B	
Audio Frequency Conducted Susceptibility	18.0	B	
Induced Signal Susceptibility	19.0	A	
Radio Frequency Susceptibility	20.0	S	Radiated Susceptibility
		T	Conducted Susceptibility
Emission of RF	21.0	B	
Lightning Induced Transient Susceptibility	22.0	A2XXX	
Lightning Direct Effects	23.0	X	not tested
Icing	24.0	X	not tested
Electrostatic Discharge (ESD)	25.0	A	
Fire, Flammability*	26.0	C	Acc. to RTC DO-160G

* Flammability Test in accordance with RTCA DO-160G instead of FAR 25.853/1359 and appendix F hereto as this is a more recent standard. DO-160D Chg. 3 does not address any aspects for fire, flammability tests.

Cat X: Not tested as no test is required explicitly by the MPS or no use in such environment is intended.

1.4.3 Housing and Human Machine Interface

ACD-57 has an all-metal housing with anti-reflective blackout finish on all parts visible to the flight crew.

ACD-57 is controlled by a dual-shaft rotary encoder with push button (not illuminated) and four softkey pushbuttons (illuminated).

Information is displayed on a backlit TFT color display. The display is sunlight readable and features a dimmable backlight.

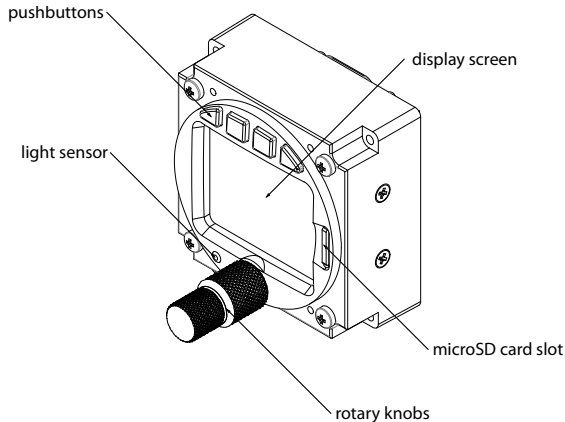

Figure 1.2.: Housing and human-machine-interface overview

1.5 Regulatory Compliance

The ACD-57 has been developed in accordance with DO-178C and DO-254 level D.

1.5.1 ETSO Functions

ACD-57 is providing the following ETSO functions:

- Type III Multifunction Display (ETSO-C113), Control of VHF-COM and Mode-S SSR transponder
- Digital output of altitude for alticoding in ATC Radar Beacon Systems (ETSO-C88a)
- Indication of measured altitude numerically and with small tape style indicator (ETSO-C10b)

1.5.2 Deviations

The following existing deviations, which have been approved by the authority are used:

1. ETSO-C10b#2/2a, Viewing envelope as per definition of ETSO-C113 and SAE 8034

2. ETSO-C10b#9, Using SAE AS8009B instead of AS392C.
3. ETSO-C10b#10, Do not display ALTITUDE or ALT next to the tape style indicator.
4. ETSO-C88a#1, Using ED-26 instead of SAE AS8003.
5. ETSO-C113#1, Using SAE AS8034A instead of AS8034.

1.5.3 Non-ETSO Functions

Non-ETSO functions provided by the ACD-57 are:

- Control of a VHF COM (e.g. channel tuning, volume control, control of specific features like "say again").
- Control of a transponder (e.g. squawk, mode, flight ID, etc.).
- Station database
- Channel memory and history
- "Nearest station" function

1.5.4 Limitations

1. Using the alticoder of ACD-57 is limited to 40,000ft (FL400).
2. Using the altimeter of ACD-57 is limited to 40,000ft (FL400).
3. Use of the device is limited to class II aircraft (MRE, MTE and STE), which includes class I aircraft (SRE), both with MTOW of 6000 pounds or less as per definition of AC23.1309-1E.
4. Use of ACD-57 as primary and only altitude measurement device of the aircraft is excluded, if loss of functions or misleading information is assessed higher than Minor.
5. The operator must verify that the installation meets the airspace requirements where the flights are intended.
6. The device does not provide static error correction. Therefore installation is limited to aircraft where static error correction is not required.

1.5.5 Installation

Conditions and tests required for TSO approval of this article are minimum performance standards. It is the responsibility of those installing this article either on or within a specific type or class of aircraft to determine that the aircraft installation conditions are within the TSO standards. TSO articles must have separate approval for installation in an aircraft. The article may be installed only if performed under applicable airworthiness requirements.

To mitigate against the loss of communication, altimetry, ATC radar beacon functionality or control thereof, installation of a second ACD-57 system may be required.

Please be aware that not all functions supported by ACD-57 may be supported by connected COM and transponder devices. Carefully observe limitations and functions of connected devices in order to assess system limitations that apply to your aircraft. Please consult the

section “COM and Transponder Compatibility Considerations” on page 18 for details on supported connected COM and transponder devices.

Certain functionality is subject to a software licensing model. In order to unlock these functions, a software license has to be purchased and a code has to be entered in the configuration menu. Please consult the section “License Management” on page 26 for details.

Unlocking of required functionality has to be done during installation and before the device is used.

1.5.6 Station Database

ACD-57 is capable of reading a COM station database from mass storage devices (microSD card).

The station database may contain errors

The flight crew is ultimately responsible for channel selection. The station database is used for reference only.

We request that the flight crew report any observed discrepancies related to database information. These discrepancies could come in the form of an incorrect channel, incorrectly identified station, or any other displayed item used for communication in the air or on the ground.

1.6 Liability

IN NO EVENT WILL AIR AVIONICS BE LIABLE FOR ANY INCIDENTAL, SPECIAL, INDIRECT OR CONSEQUENTIAL DAMAGES, WHETHER RESULTING FROM THE USE, MISUSE OR INABILITY TO USE THE PRODUCT OR FROM DEFECTS IN THE PRODUCT.

1.7 Unpacking and Inspecting Equipment

Before installation into an aircraft, the equipment should be visually inspected for shipping damages and completeness. If the unit is damaged, notify the carrier. Do not return the unit to AIR Avionics before the carrier has authorized a claim.

The following parts are normally included with ACD-57:

<i>Part</i>	<i>Part number</i>	<i>Description</i>
1 x ACD-57 main unit	ACD-57-()	ACD-57 main unit
4 x panel screws	–	M3 panel screws
1 x pressure connector	–	Removable static pressure connector

Should there be missing parts or spare parts required, please contact AIR Avionics or visit <https://www.air-store.eu>

1.8 Installation Materials

1.8.1 Tools required but not supplied

Standard Tools

<i>Tool</i>	<i>Specification</i>	<i>Description</i>
Phillips screwdriver	PH 0	Screwdriver for supplied M3 phillips screws

Special Tools

Using crimp contacts for all connectors is recommended. The table below identifies crimp tools required to ensure consistent, reliable crimp contact connections for the rear D-Sub connectors.

<i>Hand Crimping Tool</i>	<i>Positioner</i>	<i>Insertion Extraction Tool</i>
M22520/2-01	M22520-2-06	M81969/14-01

Supplied part numbers are military part numbers. Please contact AIR Avionics support or visit <https://www.air-store.eu> for procurement.

1.8.2 Parts required but not supplied

ACD-57 is intended for use with standard aviation accessories. The following items are required for installation, but not supplied.

- Wire (MIL-W-22759/16 or equivalent)
- Shielded wire (MIL-C-27500 or equivalent)
- D-SUB 15HD FEMALE connector, crimp type preferred, and crimp inserts
- D-SUB 15HD connector backshell, all metal type preferred, quicklock type preferred
- Push/Pull (manually resettable) circuit breakers
- Tie wraps or lacing cord

1.8.3 Optional Standard Kit Accessories

<i>Part number</i>	<i>Description</i>
B443	D-SUB15HD connection kit with receptacle, backshell, crimp terminals, and wire
B394	AIR Control Display to RJ45 Cable (FLARM/IGC Standard)
B427	AIR data bus Cable (D-SUB 15HD) - 1m
B428	AIR data bus Cable (D-SUB 15HD) - 3m
B429	AIR data bus Cable (D-SUB 15HD) - 5m
B430	ACD-57 (D-SUB 15HD) to VT-01 (D-SUB 9) cable - 1m
B431	ACD-57 (D-SUB 15HD) to VT-01 (D-SUB 9) cable - 3m
B489	ACD-57 (D-SUB 15HD) to Becker AVIONICS RT/AR-6201 (D-SUB 25) cable - 1m
B490	ACD-57 (D-SUB 15HD) to Becker AVIONICS RT/AR-6201 (D-SUB 25) cable - 3m
B494	ACD-57 (D-SUB 15HD) to Dittel/TQ KRT-2 (open ends) cable - 3m
B641	ACD-57 (D-SUB 15HD) to TRIG TT/TY (open ends) cable - 3m

For procurement, please visit <https://www.air-store.eu>

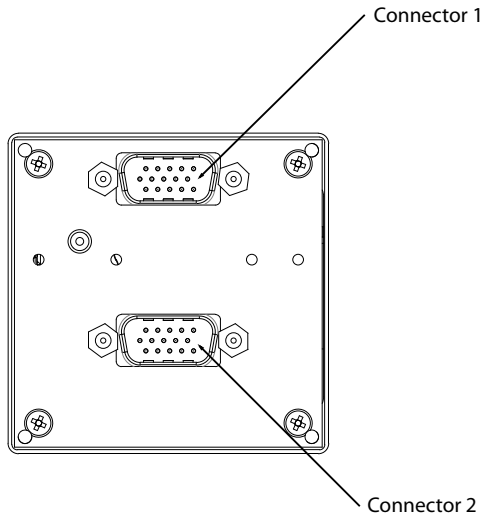

Figure 2.1.: System interconnects overview. View from the back.

Both connectors are D-SUB 15 high density male types. Small pin numbers are molded into the connectors for easier pin identification. Pin numbers of mating (female) connectors are identical, therefore mating pins have identical numbers.

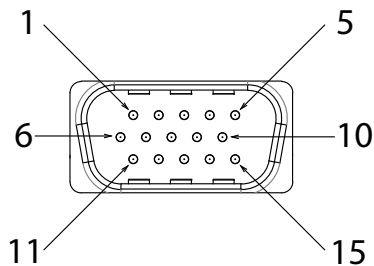

Figure 2.2.: Connector Pin Map

2.1 Pin Function List

2.1.1 Connector 1

<i>Pin Name</i>	<i>Pin number</i>	<i>I/O</i>
Aircraft Power (VIN)	1.1	In
RS-232 Port 1 receive data (RXD1)	1.2	In
RS-232 Port 1 transmit data (TXD1)	1.3	Out
Enable (EN)	1.4	Out
Aircraft Ground (GND)	1.5	-
Aircraft Power (VIN)	1.6	In
Data Bus Low Signal (CANLO)	1.7	In/Out
Data Bus High Signal (CANHI)	1.8	In/Out
Discrete Output 1 (OUT1)	1.9	Out
Discrete Output 2 (OUT2)	1.10	Out
Voltage Sensor Input 1 (USENS1)	1.11	In
Data Bus Termination 120R (CANTERM)	1.12	In
Discrete Input 1 (IN1)	1.13	In
Aircraft Ground (GND)	1.14	In
Buzzer Output 1 (BZZOUT1)	1.15	Out

2.1.2 Connector 2

<i>Pin Name</i>	<i>Pin number</i>	<i>I/O</i>
Aircraft Power (VIN)	2.1	In
RS-232 Port 2 receive data (RXD2)	2.2	In
RS-232 Port 2 transmit data (TXD2)	2.3	Out
Enable (EN)	2.4	Out
Aircraft Ground (GND)	2.5	-
Aircraft Power (VIN)	2.6	In
Data Bus Low Signal (CANLO)	2.7	In/Out
Data Bus High Signal (CANHI)	2.8	In/Out
Discrete Output 3 (OUT3)	2.9	Out
Discrete Output 4 (OUT4)	2.10	Out
Voltage Sensor Input 2 (USENS2)	2.11	In
Data Bus Termination 120R (CANTERM)	2.12	In
Discrete Input 2 (IN2)	2.13	In
Aircraft Ground (GND)	2.14	In
Buzzer Output 2 (BZZOUT2)	2.15	Out

2.2 Data Interfaces

2.2.1 Bus Data Interface

ACD-57 uses a data bus interface to connect to other AIR Avionics devices such as other ACD-57 units, aircraft radio, or air traffic control radar beacon devices (XPDR).

Only AIR Avionics articles intended for use with ACD-57 may be connected to the data bus.

Pin Name	Pin number	I/O
CAN Hi	1.8/2.8	In/Out
CAN Lo	1.7/2.7	In/Out
CANTERM	1.12/2.12	In/Out

Participating systems on a data bus are frequently referred to as “nodes”.

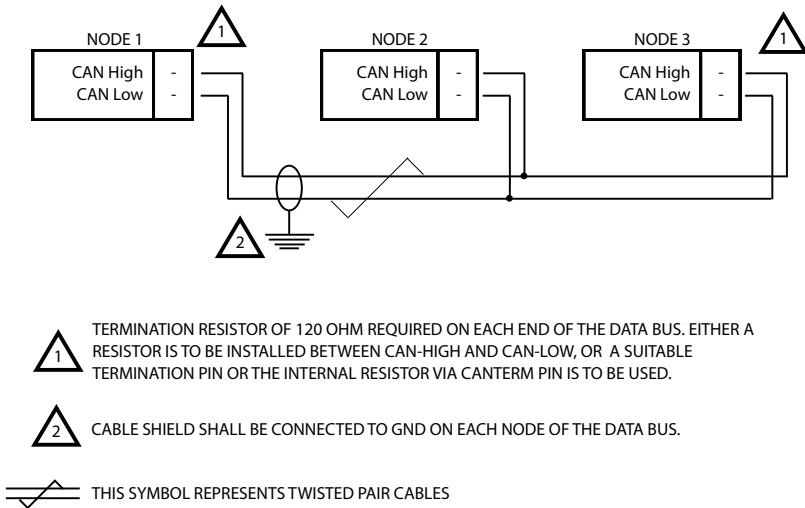

Figure 2.3.: Generic CANaerospace data bus wiring recommendation between bus nodes

The maximum recommended cable length between data bus nodes is 10 m.

The data bus interface (CANaerospace) consists of two data wires. The differential high-speed signal requires impedance controlled shielded cables or at least twisted pair shielded cables.

The data bus interface is a differential high speed signal. The data bus interface requires termination resistors to be installed on each end of the bus (120 Ohm).

On each connector, pin 12 is internally connected to the CANHI pin via a built-in 120 Ohm resistor. To terminate the bus, pin 12 can simply be connected to pin 7. In this case, external termination resistors are not required and shall not be installed. This is the recommended termination method.

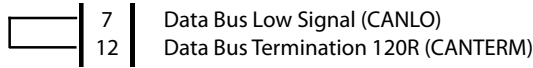

Figure 2.4.: Example for the use of the internal termination resistors. Pins 7 and 12 are connected in order to terminate the data bus.

ACD-57 sends and receives data in the CANaerospace¹ protocol. For a detailed description of supported datasets, please contact AIR Avionics support.

2.2.2 Serial Data Interface

ACD-57 is capable of interfacing with other aviation instruments by sending and/or receiving serial data on its serial ports.

Pin Name	Pin number	I/O
RS-232 Port 1 data out (TXD1)	1.3	Out
RS-232 Port 1 data in (RXD1)	1.2	In
RS-232 Port 2 data out (TXD2)	2.3	Out
RS-232 Port 2 data in (RXD2)	2.2	In

The serial outputs conform to RS-232C (EIA Standard) with a positive and negative output voltage of at least 5V when driving a standard RS-232 load.

The serial data interface (RS-232) consists of one or two data transfer wires and a ground connection. As shown in the example below, there shall always be a direct ground connection between all RS-232 clients.

It is not sufficient that power supply ground in both devices is connected to aircraft ground, an additional direct ground connection is mandatory.

The use of a twisted pair shielded cable, for example MIL-C-27500-22TG 2T14², is highly recommended. With this cable both data wires and the GND reference can be connected using a single cable.

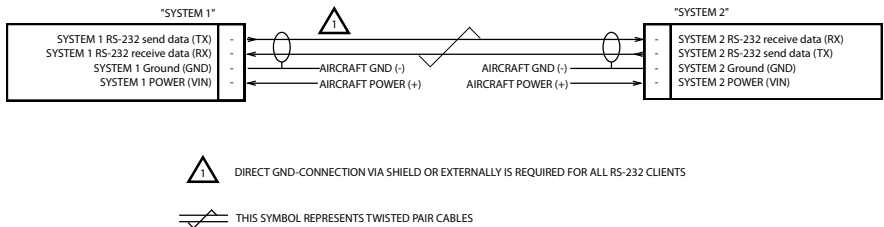

Figure 2.5.: Generic RS-232 wiring recommendation between “System 1” and “System 2”

¹To obtain the required specification, please contact “Stock Flight Systems” via <https://www.stockflightsystems.com>
²for procurement, please visit <https://www.air-store.eu>

The table below contains maximum recommended cable lengths using shielded data cables for an RS-232 data interface. Exceeding these cable lengths may reduce signal integrity and therefore the reliability of the data interface.

<i>Data Rate</i>	<i>Recommended Cable Length (meter)</i>	<i>Comment</i>
4800 Bd	30	Standard NMEA 0183 data rate
9600 Bd	15	–
19,200 Bd	7.6	–
38,400 Bd	3.7	–
57,600 Bd	2.6	–

Serial Input Protocol

ACD-57 accepts NMEA-0183 data³ on its serial inputs. While it is tolerant towards other datasets – which it discards if not required – it requires the following datasets as a minimum:

- \$GPRMC - Recommended minimum sentence C.
- \$GPGSA - GPS satellite data.
- \$GPGGA - GPS fix data.

ACD-57 accepts different data rates. ACD-57 automatically adjusts to the current data rate present on its serial inputs, if one of the following:

- 4800 baud
- 9600 baud
- 19,200 baud
- 28,800 baud
- 38,400 baud
- 57,600 baud

2.3 Power and Lighting Functions

This section covers the power input requirements and lighting bus input.

2.3.1 Power Supply

Power inputs on connector 1 and connector 2 provide power. All pins of one connector should be connected. If required, pins on both connectors may be connected.

Connector 1 and connector 2 power pins are internally decoupled. Therefore different supply voltages on the two connectors are acceptable, e.g. if a backup battery is connected to one of the two connectors.

³To obtain the required specification, please contact “National Marine Electronics Association” via <https://www.nmea.org>

For reasons of simplicity, some wiring diagrams in this manual only show one power input in use. For redundancy it is however strongly recommended to connect independent power sources to power inputs on each of the two connectors (one source per connector). In some aircraft, redundant power supply is required for using the altimeter as primary altimeter.

<i>Pin Name</i>	<i>Pin number</i>	<i>I/O</i>
Aircraft Power	1.1/1.6 or 2.1/2.6	In
Aircraft Ground	1.5 or 2.5	–

Connection of input power to incorrect pins can cause damage to the unit that will require return to the factory for repair. Ensure that the power supply is connected to the correct pins and does not short to any adjacent pins prior to applying power to the unit.

2.3.2 Lighting Bus

<i>Pin Name</i>	<i>Pin number</i>	<i>I/O</i>
Lighting Bus	1.11 or 2.11	In

Connection of the lighting bus to incorrect pins can cause damage to the unit that will require return to the factory for repair. Ensure that the lighting bus is connected to the correct pins and does not short to any adjacent pins prior to applying power to the unit, including the lighting bus.

In aircraft certified for VFR night operations, the lighting bus interface is mandatory.

2.4 Altitude Functions

If altitude functions are to be used, that is altimeter or encoding altimeter functions, the aircraft static pressure port is to be connected to the pressure connector.

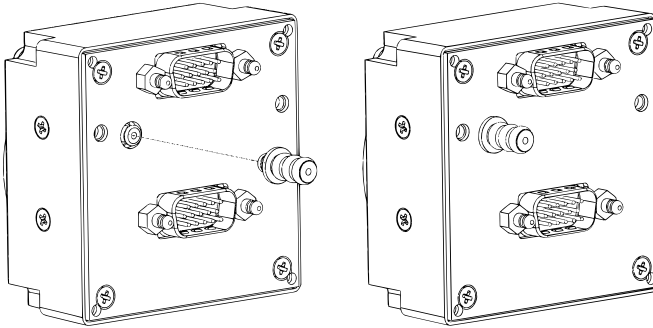

Figure 2.6.: Pressure Connector

3

Installation Overview

3.1 General Handling Recommendations

3.1.1 ESD Handling Recommendations

To avoid damage to ACD-57, take precautions to prevent Electrostatic Discharge (ESD) when handling the unit, connectors, and associated wiring. ESD damage can be prevented by touching an object that is of the same electrical potential as the unit before handling the unit itself.

3.2 Workmanship

Installation of avionics equipment into an aircraft is a complex task that requires expert skills and know-how. While some installation practices may lead to quicker results, only practices that provide for excellent durability and reliability are acceptable. As many avionics systems have a life cycle of several decades, a durable and reliable installation in compliance to strict workmanship standards is of utmost importance.

3.2.1 Workmanship

“Workmanship is defined as the control of design features, materials and assembly processes to achieve the desired durability and reliability for subassembly interconnections, specifically those in printed wiring assemblies and cable harnesses, and the use of inspection techniques and criteria to assure interconnect quality. Workmanship promotes standardized designs and fabrication practices to enhance assembly durability and reliability and restricts the use of designs and manufacturing processes known to reduce those qualities.”¹

3.2.2 Standards

Always follow acceptable avionics installation practices. Installation must always follow regulatory requirements.

Many military or civil standards for avionics installations are acceptable.

NASA Workmanship Standards

As an addition to regulatory requirements we recommend installation in accordance to NASA WORKMANSHIP STANDARDS. These standards provide for an excellent overview and in-detail knowledge on acceptable practices including explanations and a pictorial reference. NASA WORKMANSHIP STANDARDS are publicly available on this website: <https://nepp.nasa.gov/workmanship>

¹Source: <https://nepp.nasa.gov/workmanship>

Pictorial Reference

On <https://workmanship.nasa.gov> a pictorial reference “intended to provide insight to certified operators, inspectors and instructors who visually assess the compliance of flight hardware to locally applicable requirements”² is available.

3.3 Cabling and Wiring Considerations

3.3.1 General Wiring Considerations

Wiring should be installed in accordance with applicable regulations.

- It should not be possible for a cable harness to be exposed to wire chafing.
- Route the wiring bundle as appropriate. Avoid sharp bends.
- Secure all wires in order to minimize vibration damage.
- Preferably shielded wire is to be used.
- Use 22 AWG wire for all connections unless otherwise specified.
- The cable harness should not be located near flight control cables and controls, high voltage lines or fuel lines.
- The cable harness should be located in a protected area of the aircraft.
- Do not route cable near high voltage sources.

For dual ACD-57 installations, care should be taken to ensure separation between wires of redundant systems to reduce the possibility of failure due to a single event.

For the D-SUB connectors, crimp terminals and mating receptacles are recommended because these are more reliable than soldered connections, and are easier to assemble in-situ in an aircraft, where soldering is impractical. They also allow individual wires to be removed and replaced in a receptacle without replacing the whole connector.

For power supply, manually resettable circuit breakers are strongly recommended. These circuit breakers allow for individual devices to be switched off without compromising other systems on the same power bus.

3.3.2 Special Wiring Requirements for Data Bus

- Shielded wire with certain impedance characteristics must be used for differential data bus signals as specified in the interconnect drawing.
- Termination resistors are required on each end of the data bus installation.

²Source <https://workmanship.nasa.gov>

If data bus wiring requirements are not met, equipment performance may be compromised

3.4 Pressure Tubing Considerations

Pressure tubing should be installed in accordance with applicable regulations.

- Route the tubing as appropriate. Avoid sharp bends.
- Make sure the aircraft static pressure port is plumbed directly to the unit static pressure input port.
- Secure all tubes in order to minimize vibration.
- Ensure that no deformations of the airframe surface have been made that would affect the relationship between static air pressure and true ambient static air pressure for any flight condition.
- The pressure tubing should not be located near flight control cables and controls.
- ACD-57 should not be at the low point of the static plumbing lines in order to avoid moisture or debris collecting at or near the unit.
- Use care to avoid getting fluids or particles into the pneumatic port.

3.5 ACD-57 Mounting Considerations

ACD-57 is designed to be mounted in the aircraft instrument panel within view and reach of the flight crew. The primary unit location should minimize flight crew head movement when transitioning between looking outside of the cockpit and viewing/operating ACD-57. The location should be such that ACD-57 is not blocked by the glare shield on top, or by the throttles, control yoke, etc. on the bottom. Try not to mount ACD-57 in a location that is exposed to sunlight focussed by the canopy.

Be sure that any aircraft controls and emergency features do not interfere with ACD-57

3.6 COM and Transponder Compatibility Considerations

ACD-57 is designed to be interfacing to VHF Transceivers (COM) and/or ATCRBS systems (transponders). If such a system is to be interfaced in an installation case, care must be taken as to ensure that all connected devices are compatible with the ACD-57.

3.6.1 Compatible VHF Transceivers

The following VHF transceivers (COM) have been tested to be compatible to ACD-57.

<i>Device</i>	<i>P/N</i>	<i>Make</i>	<i>Interface</i>	<i>Required License</i>	<i>Tested SW Version</i>
AIR COM	AC-1-(xxxx)	AIR Avionics	Data bus	none required	AC-1-SW-(6)
AR 6201	AR6201-(022)	Becker	RS-422 via RS-232	Becker Interface	CM: 4.06, CH: 2.06
RT 6201	RT6201-(020)	Becker	RS-422 via RS-232	Becker Interface	1.51
KRT-2 (SLP)	100-(0001)-(617) 100-(0004)-(800) 100-(1106)-(850) 100-(2106)-(905)	TQ/Dittel	RS-232	KRT2 Interface	0.14, 0.18
TY91/TY92	008xx-00-(xx)	TRIG	RS-485 vis RS-232	TRIG TY	1.12

If VHF transceivers are to be connected with other than the above mentioned tested software/hardware versions, compatibility must be assessed in a per installation level.

The use of transceivers from third party manufacturers requires a function license to be installed, please consult the section “License Management” on page 26 for details on function licenses.

3.6.2 VHF Transceiver Function Limitations

Not all functions supported by ACD-57 are supported by all compatible VHF transceivers. For example not all configuration parameters required for some installations of the Dittel/TQ KRT2 can be set using ACD-57.

The following table gives an overview on functions not supported by all connected systems and other limitations thereof:

<i>Function</i>	<i>AIR COM VHF Transceiver</i>	<i>Becker 620X VHF Transceiver</i>	<i>Dittel/TQ KRT2 VHF Transceiver</i>	<i>TRIG TY91/TY92 VHF Transceiver</i>
Say Again Function	●	–	–	–
Standby COM channel independent volume level possible	●	–	–	–
VHF transceiver system configuration during installation	●	●	–	●
Interface speed from ACD-57 to VHF transceiver	fast (nearly in real time)	normal (sometimes delays are recognizable)	slow (up to half a second delay)	normal (sometimes delays are recognizable)

If the user interface of a Dittel/TQ KRT2 is used simultaneously to ACD-57 (e.g. in aircraft with a tandem seating configuration), please ensure that ACD-57 is always

switched on while KRT-2 is switched on. KRT-2 must not be switched on while ACD-57 is switched off.

3.6.3 Compatible MODE-S Transponders

The following transponders have been tested to be compatible to ACD-57:

<i>Device</i>	<i>P/N</i>	<i>Make</i>	<i>Interface</i>	<i>Required License</i>	<i>Tested SW Version</i>
VT-01	VT-0102	AIR Avionics	Data bus	none required	1.60 and newer
VT-01	VT-0104	AIR Avionics	Data bus	none required	1.60 and newer
TT21/TT22	006xx-00-(xx)	TRIG	RS-485 vis RS-232	TRIG TT	2.13

If the VT-01 is running with software version 1.60, the status of the on-the-ground mode is not shown on the ACD-57.

If MODE-S transponders are to be connected with other than the above mentioned tested software/hardware versions, compatibility must be assessed in a per installation level.

VT-01 Ultracompact may never be used if the VT-01 *Power-up Mode* is switched to ON or if the VT-01 controls are active. The installer must ensure that the VT-01 controls can not be accessed by the flight crew.

If a VT-01 Ultracompact, i.e. a VT-01 with integrated control head (part numbers VT-0104-070 and VT-0104-125) is used, please ensure that:

1. The control head of the VT-01 is never used and is never switched on.
2. The *Power-up Mode* in the VT-01 is set to OFF.

To switch *Power-up Mode* OFF in the VT-01 Ultracompact, please perform the following steps:

1. Simultaneously push key 1 (the leftmost key on the VT-01 bezel) and the inner knob pushbutton of the VT-01.
2. Enter the password 10795C.
3. Rotate the outer knob of the VT-01 to navigate to the menu *Power-up Mode*
4. Push the inner knob pushbutton of the VT-01 to access the *Power-up Mode* setup page and rotate the inner knob of the VT-01 to switch *Power-up Mode* to OFF. Execute your selection by pushing the inner knob pushbutton of the VT-01.

3.7 Air Circulation and Cooling

ACD-57 does not require external cooling. However lower operating temperatures extend equipment life. Reducing the operating temperature increases the mean time between failures (MTBF).

Units tightly installed heat each other through radiation, convection, and sometimes by direct conduction. Even a single unit operates at a much higher temperature in still air than in moving air. Fans or some other means of moving the air around electronic equipment are usually a worthwhile investment.

3.8 Compass Safe Distance

After reconfiguring the avionics in the cockpit panel, if ACD-57 is mounted less than 30 cm from the compass, recalibrate the compass and make the necessary changes for noting correction data.

4

Installation Procedures

We recommend installing ACD-57 according to the following process:

1. Equipment mounting
2. Wiring: Manufacturing and testing of wiring harness or selection of standard accessories
3. Wiring harness and interconnect installation
4. Post installation configuration, checkout, and documentation

4.1 Equipment Mounting

1. Use the dimensions shown in appendix B to prepare the mounting holes for the ACD-57 unit. Also standard templates for 57mm panel cutouts can be used.
2. Install the device in the aircraft panel using the supplied M3 screws. Secure the screws if required.

Using other screws than those supplied may cause damage to the device

4.2 Wiring

Wiring depends on many factors such as number of installed ACD-57, chosen installation options, number and type of connected devices, and aircraft specific requirements.

In most cases an individual wiring harness is manufactured. In appendix D, wiring diagrams for most common installation cases are given.

In some cases, standard accessories may be used. Appendix E holds a list of 16 example installations using standard accessories as well as recommended configuration parameters for these installations.

4.3 Interconnect Installation

1. Install all electrical connectors and ensure that they are appropriately secured. We recommend using "Quicklock" D-Sub backshells (standard configuration).
2. Install pressure tubing connector and ensure that tubing is leak-proof.

4.4 Post Installation Configuration, Checkout, and Documentation

A summary of the steps required for checkout, configuration, and installation documentation is as follows:

- Perform the installation checks. Instructions can be found in chapter 5.
- Configure the unit for the specific installation. Work through every configuration item according to instructions in chapter 6.
- Perform ground checks. Instructions can be found in chapter 7.
- Update the aircraft documentation. Instructions can be found in chapter 8.

5

Post Installation Checkout

This chapter contains instructions for checking out an ACD-57 installation. Checks shall ensure the system is properly installed and functioning correctly.

5.1 Wiring Checks

Verify that all cables are properly secured. Check the movement of aircraft controls to verify there is no interference between the cabling and controls. Ensure that all wiring is installed as described.

Prior to powering up ACD-57, the wiring harness must be checked for proper connections to the aircraft systems and other avionics equipment. Point to point continuity must be checked to expose any faults such as shorting to ground.

After accomplishing a continuity check, perform power and ground checks to verify proper power and GND levels are present. Any faults or discrepancies should be corrected at this time.

Any faults or discrepancies must be corrected before proceeding.

Make sure shielding and termination resistors are installed where appropriate

ACD-57 may be connected after completion of the continuity and power checks. All connections must be made before the unit is powered up.

5.2 Connector Engagement Checks

Prior to powering up ACD-57, a connector engagement check should be performed.

1. Optically inspect all interconnects.
2. Check if all connectors are locked properly, verify by gently pulling on the connectors.
3. Ensure that the pressure tubing sits tightly and completely covers the pressure connector.

6.1 Configuration Operations

6.1.1 Configuration Menu

ACD-57 is configured in the configuration menu. To enter the configuration menu, push the **inner knob pushbutton** for at least 2 seconds (long push). The menu contains several configuration options and informations about ACD-57 and connected systems.

Please find a menu diagram in appendix C

6.1.2 Pin Code Protection

Due to safety reasons and regulatory requirements, not all configuration parameters are readily accessible to the flight crew. Many configuration menu levels require the entry of a pin code before they can be accessed. Pin codes can be entered in *CONFIGURATION MENU* → *PIN CODE*.

Before configuration, in order to access all configuration menu levels required for installation, please enter this pin code:

Pin Code: 3000

After a correct pin code has been entered, protected menu levels are made accessible. After restart, installation mode is turned off and the pin code has to be entered again if access to protected menus is required. If configuration changes are made that require a restart of the device, the ACD-57 is restarted automatically on leaving the menu.

6.1.3 Standard Configuration Recommendations

In appendix D, a list of standard installation cases and recommended configuration parameters are given for reference.

6.1.4 Configuration Reset to Defaults

In order to reset the system configuration to factory defaults, please perform the following steps:

1. Disconnect the device from power.
2. Press and hold **Softkey 3** and **Softkey 4** while connecting the device to power. Keep holding the softkeys until the device has booted.
3. All settings are now reset to the factory defaults.

All settings will be reset and all licenses will be deleted. This process can not be undone. After factory defaults have been applied the device is no longer in an airworthy configuration state. All configuration operations have to be conducted again.

6.2 License Management

ACD-57 requires function licenses in order for some functions to be used.

A software license model ensures that ACD-57 can be offered at favorable prices to standard users while users with special function requirements can purchase functions separately. Without licenses, all users were to pay for development costs of special functions they may not need. The functionality of ACD-57 can be extended through licenses at any time, also after installation and while already being in service.

Before proceeding system configuration, all required function licenses must be installed!

6.2.1 Function Licenses

Special functions are only available if "unlocked" by entering a valid license installation code. The license installation code is a multi digit code. Installed function licenses can be reviewed in *CONFIGURATION MENU* → *LICENSES*.

Licenses are required for the following functions:

- Display and use of the integrated altitude indicator (altimeter).
- Control of BECKER 620X VHF Transceivers (COM), once installed this license never expires.
- Control of DITTEL/TQ KRT2 VHF Transceivers (COM), once installed this license never expires.

If none of the above mentioned functions are to be used, no license has to be installed. In this case, skip this section.

6.2.2 Purchasing Function Licenses

Function licenses can exclusively be purchased online in the *AIR Avionics License Store*.

Please visit <https://www.air-store.eu> for details.

6.2.3 Function License Installation

To install a license, please carry out the following steps:

1. Open the menu with a long push on the **inner knob pushbutton**.
2. Use the **inner knob** to navigate to *CONFIGURATION MENU* → *LICENSE* → *INSTALL*.

3. Enter a valid license installation code: Use the **inner knob** to select a character. Use the **outer knob** to select a digit.
4. Push the **inner knob pushbutton** to execute your selection.
5. After the license installation code has been successfully validated, the license is installed. Verify correct installation in the license list.
6. Push the **ESC softkey** to leave the menu.

6.3 Device Configuration

In the configuration menu, *DEVICE* contains specific configuration parameters and information about the ACD-57 device itself.

6.3.1 Info

In the *DEVICE* menu, *INFO* contains specific information about the ACD-57 device such as hardware and software version information.

6.3.2 Status

In the *DEVICE* menu, *STATUS* contains information about the power supply voltage, the position data source, and the pressure data source.

6.3.3 Illumination Override

In the *DEVICE* menu, *ILLUMIN OVERRIDE* the current display and knob illumination level can be manually set.

Until the next restart of the ACD-57, this setting overrides the current illumination configuration that has been entered during device installation. After a restart, the illumination configuration that has been entered during installation is restored.

To override the illumination configuration, please carry out the following steps:

1. Open the menu with a long push on the **inner knob pushbutton**.
2. Use the **inner knob** to navigate to *DEVICE* → *ILLUMIN OVERRIDE*
3. Once the illumination override page is entered, the illumination configuration is shown. Use the **inner knob** to override the illumination configuration and to enter a manual value.
4. Push the **inner knob pushbutton** to execute your selection.
5. Push the **ESC softkey** to leave the menu.

To reset the override and get back to the illumination configuration entered during installation, push the **RESET softkey**.

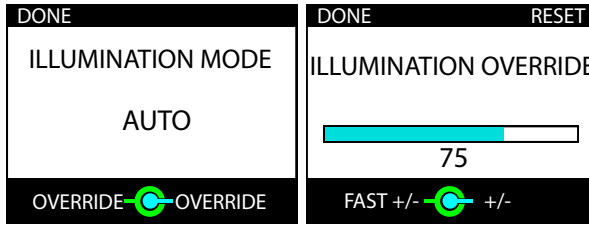

Figure 6.1.: Illumination override page. On the left the automatic illumination configuration is active, current illumination mode is shown. On the right the override is active.

6.3.4 Alert Sounder Volume

ACD-57 features an integrated alert sounder (buzzer) for failure and warning annunciation. Alert sounder volume can be adjusted to meet individual installation requirements. The default for this value is 3.

To change the alert sounder volume, please carry out the following steps:

1. Open the menu with a long push on the **inner knob pushbutton**.
2. Use the **inner knob** to navigate to *DEVICE* → *INSTALLATION* → *SOUNDER VOLUME*
3. Use the **inner knob** to select a desired volume.
4. Push the **inner knob pushbutton** to execute your selection.
5. Push the **ESC softkey** to leave the menu.

6.3.5 HMI Illumination Brightness Control

Human machine interface (HMI) illumination brightness (screen and buttons) can be controlled using independent methods, only one brightness control method can be used at a time.

- Manual brightness control - Brightness at a set value (user adjustable).
- Automatic brightness control - Automatic adjustment using the ambient light sensor
- Brightness control over aircraft lighting bus - using one of the lighting bus inputs

For aircraft operating at night, the aircraft lighting bus input must be used.

The value for manual, minimum, and maximum illumination levels can be configured individually. Aircraft lighting bus source and minimum/maximum voltage values can as well be configured.

Please note that some changes like minimum and maximum illumination level require a system restart before they take effect.

Manual Brightness Control

To change the HMI illumination mode to manual brightness control, please carry out the following steps:

1. Open the menu with a long push on the **inner knob pushbutton**.
2. Use the **inner knob** to navigate to *DEVICE* → *INSTALLATION* → *ILLUMINATION* → *MODE*.
3. Use the **inner knob** to select *MANUAL*.
4. Push the **inner knob pushbutton** to execute your selection.
5. Push the **ESC softkey** to leave the menu.

Now the brightness level as configured in *MANUAL INTENSITY* is used.

Automatic Brightness Control

To change the HMI illumination mode to automatic brightness control, please carry out the following steps:

1. Open the menu with a long push on the **inner knob pushbutton**.
2. Use the **inner knob** to navigate to *DEVICE* → *INSTALLATION* → *ILLUMINATION* → *MODE*.
3. Use the **inner knob** to select *AUTO*.
4. Push the **inner knob pushbutton** to execute your selection.
5. Push the **ESC softkey** to leave the menu.

Now the brightness level is adjusted using the ambient light sensor in the front bezel of the device. Restrictions to minimum and maximum brightness levels are configured in *MINIMUM* and *MAXIMUM*.

Brightness Control over Aircraft Lighting Bus

In order to use the aircraft lighting bus, the following configuration actions have to be taken:

1. change HMI illumination mode
2. configure the input pin used
3. configure input voltage levels

To change the HMI illumination mode to aircraft lighting bus, please carry out the following steps:

1. Open the menu with a long push on the **inner knob pushbutton**.
2. Use the **inner knob** to navigate to *DEVICE* → *INSTALLATION* → *ILLUMINATION* → *MODE*.
3. Use the **inner knob** to select *LIGHTINGBUS*.
4. Push the **inner knob pushbutton** to execute your selection.

5. Push the **ESC softkey** to leave the menu.

To configure the correct input pin for the lighting bus, please carry out the following steps:

1. Open the menu with a long push on the **inner knob pushbutton**.
2. Use the **inner knob** to navigate to *DEVICE* → *INSTALLATION* → *ILLUMINATION* → *LIGHTING BUS* → *LIGHT. BUS SRC.*
3. Use the **inner knob** to select *select the pin, the aircraft lighting bus is connected to (USENS1 or USENS2).*
4. Push the **inner knob pushbutton** to execute your selection.
5. Push the **ESC softkey** to leave the menu.

Now the brightness level is adjusted using the configured lighting bus input pin. To configure desired voltage levels for minimum and maximum brightness, please carry out the following steps:

1. Open the menu with a long push on the **inner knob pushbutton**.
2. Use the **inner knob** to navigate to *DEVICE* → *INSTALLATION* → *ILLUMINATION* → *LIGHTING BUS* → *LIGHT. BUS MIN.*
3. set the aircraft lighting bus to the minimum level using the lighting bus control in your aircraft.
4. Push the **inner knob pushbutton** to execute your selection.
5. Use the **inner knob** to navigate to *DEVICE* → *INSTALLATION* → *ILLUMINATION* → *LIGHTING BUS* → *LIGHT. BUS MAX.*
6. set the aircraft lighting bus to the maximum level using the lighting bus control in your aircraft.
7. Push the **inner knob pushbutton** to execute your selection.
8. Push the **ESC softkey** to leave the menu.

6.3.6 Power On Mode

“Power On Mode” is typically active (set to ON) in order to always automatically switch ACD-57 on if sufficient supply power is present. By setting the Power On Mode to OFF ACD-57 ignores supply power and is switched on by pushing **softkey 1**.

As mentioned above, the default setting for this parameter is *ON*. To change Power On Mode configuration, please carry out the following steps:

1. Open the menu with a long push on the **inner knob pushbutton**.
2. Use the **inner knob** to navigate to *DEVICE* → *INSTALLATION* → *POWER ON MODE.*
3. Push the **inner knob pushbutton** to toggle between ON and OFF.
4. Push the **ESC softkey** to leave the menu.

6.3.7 Data Ports

GPS Source

ACD-57 has two independent RS-232 data ports and a CAN data bus interface. Both RS-232 data ports can be used to accept data from an RS-232 NMEA GPS source, and the CAN data bus can accept GPS information e.g. from another ACD-57. This menu parameter has to be configured if a GPS source is connected. The default setting for this parameter is *NOT CONNECTED*.

To change the GPS source configuration, please carry out the following steps:

1. Open the menu with a long push on the **inner knob pushbutton**.
2. Use the **inner knob** to navigate to *DEVICE* → *INSTALLATION* → *DATA PORTS* → *GPS SOURCE*.
3. Use the **inner knob** to select a source: *RS-232 1* (uses data port on upper connector), *RS-232 2* (uses data port on lower connector), or *DATA BUS* (for the data bus).
4. Push the **inner knob pushbutton** to execute your selection.
5. Push the **ESC softkey** to leave the menu.

If a VT-01 Mode-S transponder is connected to this ACD-57 and GPS data shall be used for ADS-B out, only an RS-232 GPS source with standard NMEA datasets and a data rate of 4800 baud is acceptable.

Share GPS Data

This parameter can be switched *ON* in order to propagate current GPS position data to other devices on the same data bus. The default setting for this parameter is *OFF*.

For example in multi systems installations, only one GPS source has to be connected to a single ACD-57, where the *SHARE GPS DATA* parameter is set to *ON*. Other units can then use the GPS position data shared by this ACD-57.

To change the configuration for GPS position sharing via the data bus, please carry out the following steps:

1. Open the menu with a long push on the **inner knob pushbutton**.
2. Use the **inner knob** to navigate to *DEVICE* → *INSTALLATION* → *DATA PORTS* → *SHARE GPS DATA*.
3. Push the **inner knob pushbutton** to toggle between *ON* and *OFF*.
4. Push the **ESC softkey** to leave the menu.

If switching *SHARE GPS DATA* to *ON*. Please ensure that a GPS source is connected to one of the RS-232 data ports and that the *GPS SOURCE* parameter is configured correctly.

Data Bus Node ID

The data bus node ID is a unique identifier in a data bus. Every device must have a unique node ID. Therefore, when installing multiple ACD-57 devices in one data-bus, node IDs have to be entered accordingly.

The value range from 100 to 109 is reserved for ACD-57 in a data bus installation. The default node id entered in the factory is 100.

It is recommended to enter the following IDs in multi-ACD-57 installations:

- first ACD-57: Node ID 100 (factory default)
- second ACD-57: Node ID 101
- third ACD-57: Node ID 102
- fourth ACD-57: Node ID 103

To change the data bus node-id, please carry out the following steps:

1. Open the menu with a long push on the **inner knob pushbutton**.
2. Use the **inner knob** to navigate to *DEVICE → INSTALLATION → DATA PORTS → DATA BUS NODE-ID*.
3. Use the **inner knob** to select the desired value.
4. Push the **inner knob pushbutton** to execute your selection.
5. Push the **ESC softkey** to leave the menu.

Serial Control Interface

The ACD-57 can be remote controlled by third party devices via a serial connection. The protocol specification is public and can be found in appendix F.

If you want to control your ACD-57 with a non-certified device, you have to make sure your installation fulfills all regulatory requirements (see e.g. EASA Certification Memorandum CM-AS-007).

To reduce latency in an multi-seat configuration, it is recommended to connect the controlling device to the same ACD-57 as a third party device that is controlled by the ACD-57 via a serial connection (e.g. a third party COM device), although it might be connected to any of the ACD-57.

To enable the serial control interface, please carry out the following steps:

1. Open the menu with a long push on the **inner knob pushbutton**.
2. Use the **inner knob** to navigate to *DEVICE → INSTALLATION → DATA PORTS → CONTROL INTERFACE → DATA PORT*.
3. Use the **inner knob** to select a port: *RS-232 1* (uses data port on upper connector), *RS-232 2* (uses data port on lower connector), or *NOT CONNECTED* (to disable).
4. Push the **inner knob pushbutton** to execute your selection.
5. Push the **ESC softkey** to leave the menu.

To set the data rate for the serial connection, please carry out the following steps:

1. Open the menu with a long push on the **inner knob pushbutton**.
2. Use the **inner knob** to navigate to *DEVICE → INSTALLATION → DATA PORTS → CONTROL INTERFACE → BAUDRATE*.

3. Use the **inner knob** to select a value: *AUTO* (for automatic data rate selection), or one of the other values for a fixed data rate.
4. Push the **inner knob pushbutton** to execute your selection.
5. Push the **ESC softkey** to leave the menu.

Note that while you can use the same port as in your GPS source setting (if the controlling device also provides location data), it is not possible to connect a third party COM device to the same port as the control interface.

If you set the baud rate to *AUTO*, the ACD-57 will not send any data on this port before it has received some data to determine the connection speed.

6.3.8 Load Configuration File

It is possible to configure the ACD-57 using a configuration file on a microSD card. To do so, the configuration file must be placed on the microSD card, the filename must end with ".txt" and there must be only one ".txt" file on the card. Insert the microSD card before the ACD-57 is powered on. Then carry out the following steps:

1. Open the menu with a long push on the **inner knob pushbutton**.
2. Use the **inner knob** to navigate to *DEVICE* → *INSTALLATION* → *LOAD CFG FILE*.
3. Push the **inner knob pushbutton** to execute your selection.

You can find an example configuration file on <https://www.air-avionics.com>.

6.4 Altimeter Configuration

The *ALTIMETER* menu section contains specific configuration parameters for the integrated altimeter.

6.4.1 Units

Units for altitude and pressure are user configurable.

- Altitude units configurable to meters or feet
- Pressure units configurable to hectopascals (millibars) or inches of mercury

The default settings are *meters* and *hectopascals*. To change the altimeter units configuration, please carry out the following steps:

1. Open the menu with a long push on the **inner knob pushbutton**.
2. Use the **inner knob** to navigate to *ALTIMETER* → *UNITS*.
3. Use the **inner knob** to navigate to a unit category, use the **inner knob pushbutton** to enter the menu.
4. Use the **inner knob** to select the desired unit.
5. Push the **inner knob pushbutton** to execute your selection.
6. Push the **ESC softkey** to leave the menu.

6.4.2 Altimeter Display

This parameter can be switched *ON* in order to show the altimeter user interface. If switched to *OFF*, the altimeter is not shown. If the altimeter function is to be used, this parameter shall be switched to *ON*. The default setting for this parameter is *OFF*.

To change altitude display configuration, please carry out the following steps:

1. Open the menu with a long push on the **inner knob pushbutton**.
2. Use the **inner knob** to navigate to *ALTIMETER* → *INSTALLATION* → *ALT DISPLAY*.
3. Push the **inner knob pushbutton** to toggle between *ON* and *OFF*.
4. Push the **ESC softkey** to leave the menu.

Barometric Source

ACD-57 has a static port for static pressure/altitude measurement. Either the static port can be used for altitude measurement, or an altitude signal can be obtained from another altitude source (for example a second ACD-57 on the same data bus).

The parameter *BARO SOURCE* shall be switched to *STATIC PORT*, if the static port is in use. If the altitude is to be obtained from another unit in the data bus, it shall be set to *DATA BUS*. As a third option, the parameter can be set to *NOT CONNECTED*. This is only recommended in special cases. The default setting for this parameter is *STATIC PORT*.

To change the barometric source configuration, please carry out the following steps:

1. Open the menu with a long push on the **inner knob pushbutton**.
2. Use the **inner knob** to navigate to *ALTIMETER* → *INSTALLATION* → *BARO SOURCE*.
3. Use the **inner knob** to select a source: *NOT CONNECTED*, *STATIC PORT* (uses static port), or *DATA BUS* (uses altitude from other source on the data bus).
4. Push the **ESC softkey** to leave the menu.

Share Altitude

This parameter can be set to *YES* in order to propagate current altitude data to other devices in the same data bus. The default setting for this parameter is *NO*.

For example in multi-systems-installations, only one static pressure/altitude source has to be connected to a single ACD-57, where the *SHARE ALTITUDE* parameter is set to *YES*. Other units can then use the static pressure/altitude data shared by this ACD-57.

To change the configuration for sharing altitude data on the data bus, please carry out the following steps:

1. Open the menu with a long push on the **inner knob pushbutton**.
2. Use the **inner knob** to navigate to *ALTIMETER* → *INSTALLATION* → *SHARE ALTITUDE*.
3. Push the **inner knob pushbutton** to toggle between ON and OFF.
4. Push the **ESC softkey** to leave the menu.

If setting *SHARE ALTITUDE* to *YES*. Please ensure that a static pressure source is connected to the static port and that the *BARO SOURCE* parameter is set to *STATIC PORT*.

6.5 ACD-57 COM Control Configuration

The *COM CONTROL* menu section contains setup parameters for the control of a connected COM system.

6.5.1 Channel Spacing

The “channel spacing” setting selects which frequencies / channels can be dialed in by the ACD-57. With the default setting (*BOTH*) all 25 kHz frequencies and 8.33 kHz channels can be selected by either rotating the (inner knob) or simultaneously pushing the (inner knob pushbutton) and rotating the (inner knob) (25 kHz increments for faster adjustment).

Don't change this setting if you are not absolutely sure what you are doing. If your country uses 8.33 kHz channels, you will most likely still encounter stations with 25 kHz frequencies (like FIS). With those stations you might not hear their reply if you dial in the corresponding 8.33 kHz channel due to climax operation. If your country only uses 25 kHz frequencies, then set the spacing to 25kHz.

If the “channel spacing” is set to 25kHz or 8.3kHz, only the corresponding frequencies / channels can be dialed in. Note that for regular use you never want to set this to 8.3kHz.

To change the channel spacing configuration, please carry out the following steps:

1. Open the menu with a long push on the (inner knob pushbutton).
2. Use the (inner knob) to navigate to *COM CONTROL* → *CHN SPACING*.
3. Use the (inner knob) to select a desired spacing (*BOTH*, 25kHz, or 8.3kHz).
4. Push the (inner knob pushbutton) to execute your selection.
5. Push the (ESC softkey) to leave the menu.

6.5.2 Station Names

This parameter can be switched to *ON* in order to show station names on the main page of the COM user interface. If set to *OFF*, station names are not shown on the main page, but are still shown and used on other pages. The default setting for this parameter is *ON*.

The display of station names in ACD-57 requires GPS position data and an installed station database (microSD card). If no GPS position data or no station database is available, station names are not shown and position based radio channel selection is disabled.

Station names are only shown for stations within a distance of approx. 20 miles from the aircraft's current position.

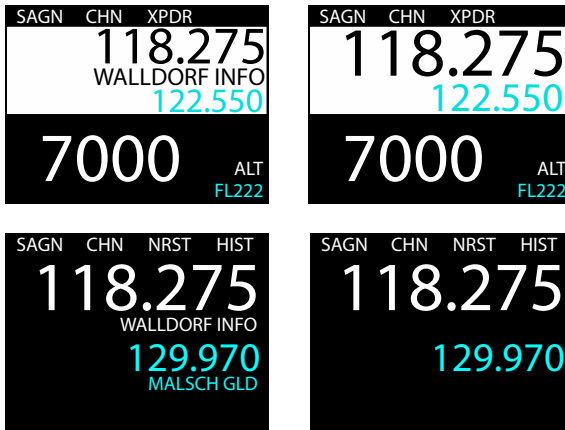

Figure 6.2.: COM main page with *STATION NAMES* parameter set to *ON* on the left and to *OFF* on the right. Please note that in COM only configuration, station names for both standby and active channel are shown. In all other configurations, only the active channel station name is shown.

To change this configuration, please carry out the following steps:

1. Open the menu with a long push on the **inner knob pushbutton**.
2. Use the **inner knob** to navigate to *COM CONTROL* → *STATION NAMES*.
3. Push the **inner knob pushbutton** to toggle between YES and NO.
4. Push the **ESC softkey** to leave the menu.

6.5.3 Knob Use

With this parameter the primary use of the **inner knob** and **outer knob** on the main page can be selected. The **inner knob pushbutton** function remains unaffected of this setting (always toggles active/standby channels). The default setting for this parameter is *VOLUME*.

It can be set to *VOLUME* in order to open the volume control page when turning the **inner knob** or the **outer knob**. In this case **softkey 2** will have the function to open the channel selection page.

It can also be set to *CHANNEL* in order to open the channel selection page when turning the **inner knob** or the **outer knob**. In this case **softkey 2** will have the function to open the volume control page.

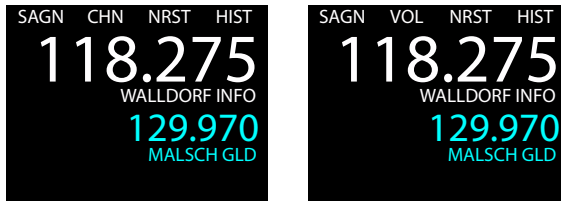

Figure 6.3.: COM main page with *KNOB USE* parameter set to *VOLUME* on the left and to *CHANNEL* on the right.

In aircraft with no audio panel or intercom, we recommend to use the default setting (*KNOB USE* set to *VOLUME*). If an audio panel/intercom is used, it may not be required to change COM volume frequently. In this case, setting the *KNOB USE* parameter to *CHANNEL* is recommended for easier channel selection.

To change the knob use configuration, please carry out the following steps:

1. Open the menu with a long push on the **inner knob pushbutton**.
2. Use the **inner knob** to navigate to *COM CONTROL* → *KNOB USE*.
3. Use the **inner knob** to select a desired option (*VOLUME* or *CHANNEL*).
4. Push the **inner knob pushbutton** to execute your selection.
5. Push the **ESC softkey** to leave the menu.

6.5.4 COM Display

The *COM DISPLAY* parameter can be switched *ON* in order to show the COM user interface. If switched *OFF*, COM controls are not shown. If a COM system is connected and shall be controlled, this parameter shall be switched to *ON*. The default setting for this parameter is *OFF*.

To change COM display configuration, please carry out the following steps:

1. Open the menu with a long push on the **inner knob pushbutton**.
2. Use the **inner knob** to navigate to *COM CONTROL* → *INSTALLATION* → *COM DISPLAY*.
3. Push the **inner knob pushbutton** to toggle between *ON* and *OFF*.
4. Push the **ESC softkey** to leave the menu.

6.5.5 COM Type

In *COM TYPE* the type of the controlled COM unit is selected. The default setting for this parameter is *AIR COM*.

It is important to always select the correct type of COM unit, even if the COM unit is controlled by a different ACD-57 in a multi ACD-57 installation.

To change COM type configuration, please carry out the following steps:

1. Open the menu with a long push on the **inner knob pushbutton**.

2. Use the **inner knob** to navigate to *COM CONTROL* → *INSTALLATION* → *COM TYPE*.
3. Use the **inner knob** to select a desired type (*AIR COM*, *BECKER* or *KRT2*).
4. Push the **inner knob pushbutton** to execute your selection.
5. Push the **ESC softkey** to leave the menu.

COM Source

ACD-57 has two RS-232 data ports and a data bus interface. Depending on the controlled COM type, either one of the RS-232 data ports or the data bus is used to interface the COM system. The default setting for this parameter is *DATA BUS*.

In multi ACD-57 installations, the data bus can be used for controlling a com unit that is connected to an other ACD-57 (for example on an RS-232 port of the other display).

To change the COM source configuration, please carry out the following steps:

1. Open the menu with a long push on the **inner knob pushbutton**.
2. Use the **inner knob** to navigate to *COM CONTROL* → *INSTALLATION* → *COM SOURCE*.
3. Use the **inner knob** to select a source: *DATA BUS* (if the COM system is connected to another ACD-57), *PORT 1* (COM system connected to upper connector), or *PORT 2* (COM system connected to lower connector).
4. Push the **inner knob pushbutton** to execute your selection.
5. Push the **ESC softkey** to leave the menu.

As an example, in an installation with two ACD-57, if a COM unit is connected to the upper port on one ACD-57, the *COM SOURCE* parameter on this ACD-57 is set to the *PORT 1*. On the second display (where the COM unit is not directly connected) the *COM SOURCE* parameter is set to *DATA BUS*. The table below shows recommended settings. Please note that *COM SOURCE* in the second (optional) ACD-57 is set to *DATA BUS*.

<i>COM Type</i> <i>Type of COM unit in the aircraft</i>	<i>COM SOURCE first ACD-57</i> <i>COM directly connected</i>	<i>COM SOURCE second ACD-57</i> <i>Other ACD-57, no COM connected</i>
AIR COM	PORT 1 or PORT 2	DATA BUS
Becker 620X	PORT 1 or PORT 2	DATA BUS
KRT2	PORT 1 or PORT 2	DATA BUS

6.6 Connected COM System Configuration

The *COM SYSTEM* section contains setup parameters for a connected VHF transceiver. Depending on the type of connected VHF transceiver, different parameters are available. Where possible, menu parameter names are consistent to parameter names in the VHF transceiver's documentation.

Please note in dual ACD-57 installations that if a Becker 620X, TRIG TY9x, or Dittel/TQ KRT2 is controlled, the *COM SYSTEM* menu section is only available on the display the VHF transceiver is directly connected to.

Please consult the VHF transceiver's documentation for details on parameters and recommended values.

6.7 ACD-57 XPDR Control Configuration

The *XPDR CONTROL* section contains setup parameters for the control of a connected XPDR system.

6.7.1 VFR Preset

Here a preset value for the VFR squawk code can be entered. This value is used when the *VFR Softkey* is pressed on the XPDR page.

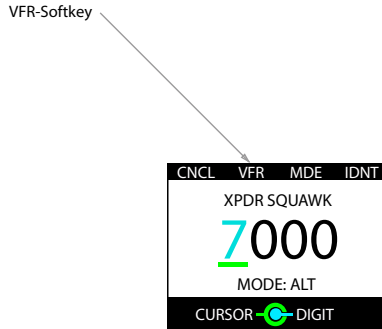

Figure 6.4.: **VFR softkey** on the XPDR page. The squawk code entered in the *VFR PRESET* parameter is set if the softkey is pushed.

To change the VFR squawk code preset, please carry out the following steps:

1. Open the menu with a long push on the **inner knob pushbutton** .
2. Use the **inner knob** to navigate to *XPDR CONTROL* → *VFR PRESET*.
3. Use the **outer knob** to select a position/digit and the **inner knob** to change the value at this position.
4. Push the **inner knob pushbutton** to execute your selection.
5. Push the **ESC softkey** to leave the menu.

6.7.2 XPDR Display

This parameter can be switched *ON* in order to show the XPDR user interface. If switched to *OFF*, XPDR controls are not shown. If a XPDR system is connected and shall be controlled, this parameter shall be switched to *ON*. The default setting for this parameter is *OFF*.

To change XPDR display configuration, please carry out the following steps:

1. Open the menu with a long push on the **inner knob pushbutton** .
2. Use the **inner knob** to navigate to *XPDR CONTROL* → *INSTALLATION* → *XPDR DISPLAY*.
3. Push the **inner knob pushbutton** to toggle between *ON* and *OFF*.

4. Push the **ESC softkey** to leave the menu.

6.7.3 XPDR Type

In *XPDR TYPE* the type of the controlled transponder unit is selected. Currently only the AIR Avionics VT01 is supported. The default setting for this parameter is *VT01*.

To change transponder type configuration, please carry out the following steps:

1. Open the menu with a long push on the **inner knob pushbutton**.
2. Use the **inner knob** to navigate to *XPDR CONTROL* → *INSTALLATION* → *XPDR TYPE*.
3. Use the **inner knob** to select a desired type (currently only *VT01*).
4. Push the **inner knob pushbutton** to execute your selection.
5. Push the **ESC softkey** to leave the menu.

XPDR Source

As a VT-01 transponder uses a special data interface it is required to configure the exact port (connector) to which the transponder is connected to, that is either *PORT 1* for the upper connector or *PORT 2* for the lower connector.

In multi ACD-57 installations, *XPDR SOURCE* is set to *DATA BUS* on the second display where the transponder is not directly connected. *DATA BUS* is the default value.

The default setting for this parameter is *DATA BUS*.

To change the XPDR source configuration, please carry out the following steps:

1. Open the menu with a long push on the **inner knob pushbutton**.
2. Use the **inner knob** to navigate to *XPDR CONTROL* → *INSTALLATION* → *XPDR SOURCE*.
3. Use the **inner knob** to select a source: *DATA BUS* (for the data bus), *PORT 1* (connected to upper connector), or *PORT 2* (connected to lower connector).
4. Push the **inner knob pushbutton** to execute your selection.
5. Push the **ESC softkey** to leave the menu.

As an example, in an installation with two ACD-57, if a transponder unit is connected the upper port of one ACD-57, the *XPDR SOURCE* parameter on this ACD-57 is set to the *PORT 1*. On the second ACD-57 (where the transponder unit is not directly connected) the *XPDR SOURCE* parameter is set to *DATA BUS*.

6.8 Connected XPDR System Configuration

The *XPDR SYSTEM* section contains setup parameters for a connected XPDR system. Please consult the XPDR system's documentation for details on parameters and recommended values.

Note that for the VT-01, the system state, software versions, and configuration is not known to the ACD-57 unless the VT-01 has been set to ALT mode at least once during the runtime of the ACD-57.

Please note in dual ACD-57 installations that if a TRIG TT2x is controlled, the *XPDR SYSTEM* menu section is only available on the display the transponder is directly connected to.

This section contains setup parameters of a connected XPDR system. It only shows parameters supported by ACD-57 and how they are changed. For details on recommended settings and all available parameters of the connected XPDR system, please consult the XPDR system's documentation.

6.8.1 Flight ID

In this menu, a flight ID can be entered. The flight ID must correspond to the aircraft identification specified in item 7 of the ICAO flight plan, or, when no flight plan has been filed, the aircraft registration.

To enter a flight ID, please carry out the following steps:

1. Open the menu with a long push on the **inner knob pushbutton**.
2. Use the **inner knob** to navigate to *XPDR SYSTEM* → *FLIGHT ID*.
3. Use the **outer knob** to select a position/digit and the **inner knob** to change the value at this position.
4. Push the **inner knob pushbutton** to execute your selection.
5. Push the **ESC softkey** to leave the menu.

6.8.2 ICAO24 Address

Mode-S relies on a unique ICAO 24-bit aircraft address for selective interrogation of an individual aircraft.

In order to use Mode-S, the ICAO 24-bit aircraft address (also called ICAO-Address or HEX-CODE) has to be entered in hexadecimal notation. Without the address being entered, the connected XPDR system will only reply to MODE-C requests.

The correct address is either stored in the aircraft's maintenance log, or, if not available yet, can be obtained from local aviation authorities.

To enter an ICAO24 address, please carry out the following steps:

1. Open the menu with a long push on the **inner knob pushbutton**.

2. Use the **inner knob** to navigate to *XPDR SYSTEM* → *INSTALLATION* → *ICAO ADDRESS*.
3. Use the **outer knob** to select a position/digit and the **inner knob** to change the value at this position.
4. Push the **inner knob pushbutton** to execute your selection.
5. Push the **ESC softkey** to leave the menu.

Maximum Speed Category

In this menu, the maximum speed category of the aircraft shall be entered. The default value is 0. To enter a maximum speed category, please carry out the following steps:

1. Open the menu with a long push on the **inner knob pushbutton**.
2. Use the **inner knob** to navigate to *XPDR SYSTEM* → *INSTALLATION* → *MAX SPEED CAT*.
3. Use the **inner knob** to select a category. Choose 0 if the category is unknown.
4. Push the **inner knob pushbutton** to execute your selection.
5. Push the **ESC softkey** to leave the menu.

6.8.3 ADS-B Configuration

In this menu, the following ADS-B related parameters are configured:

1. ADS-B In availability
2. ADS-B aircraft category
3. ADS-B L/W code
4. ADS-B Inhibit

ADS-B In availability

This parameter shall be set to *YES* if the aircraft is ADS-B IN capable, i.e. if an ADS-B receiver is installed. Default value of this parameter is *NO*.

To change the ADS-B In availability parameter, please carry out the following steps:

1. Open the menu with a long push on the **inner knob pushbutton**.
2. Use the **inner knob** to navigate to *XPDR SYSTEM* → *INSTALLATION* → *ADS-B CONFIG* → *ADS-B IN AVAIL*.
3. Use the **inner knob** to select a value.
4. Push the **inner knob pushbutton** to execute your selection.
5. Push the **ESC softkey** to leave the menu.

ADS-B aircraft category

In this menu, the ADS-B aircraft category shall be entered. The default value is 24. To enter an aircraft category, please carry out the following steps:

1. Open the menu with a long push on the **inner knob pushbutton**.

2. Use the **inner knob** to navigate to *XPDR SYSTEM* → *INSTALLATION* → *ADS-B CONFIG* → *ADS-B ACFT CAT.*
3. Use the **inner knob** to select a category. Choose 24 if the category is unknown.
4. Push the **inner knob pushbutton** to execute your selection.
5. Push the **ESC softkey** to leave the menu.

ADS-B L/W code

In this menu, the ADS-B length/width code shall be entered. The default value is 0. To enter an L/W code, please carry out the following steps:

1. Open the menu with a long push on the **inner knob pushbutton**.
2. Use the **inner knob** to navigate to *XPDR SYSTEM* → *INSTALLATION* → *ADS-B CONFIG* → *ADS-B L/W CODE.*
3. Use the **inner knob** to select a code. Choose 0 if the code is unknown.
4. Push the **inner knob pushbutton** to execute your selection.
5. Push the **ESC softkey** to leave the menu.

6.8.4 ADS-B Inhibit

Here the ADS-B Out feature of a connected XPDR system can be inhibited (i.e. switched off). The default value for this parameter is *OFF*. If the parameter is set to *ON*, no ADS-B data is transmitted by the XPDR.

To change the ADS-B active state of the XPDR, please carry out the following steps:

1. Open the menu with a long push on the **inner knob pushbutton**.
2. Use the **inner knob** to navigate to *XPDR SYSTEM* → *INSTALLATION* → *ADS-B CONFIG* → *ADS-B INHIBIT.*
3. Use the **inner knob** to select a state.
4. Push the **inner knob pushbutton** to execute your selection.
5. Push the **ESC softkey** to leave the menu.

6.8.5 XPDR Configuration

On-Ground-Switch

This parameter shall be configured to the value *ON* if an On-Ground-Switch is installed in the aircraft and connected to the XPDR. Default value for this parameter is *OFF*.

To change the On-Ground-Switch configuration of the XPDR, please carry out the following steps:

1. Open the menu with a long push on the **inner knob pushbutton**.
2. Use the **inner knob** to navigate to *XPDR SYSTEM* → *INSTALLATION* → *XPDR CONFIG* → *ON GND SWITCH.*

3. Use the **inner knob** to select a state.
4. Push the **inner knob pushbutton** to execute your selection.
5. Push the **ESC softkey** to leave the menu.

XPDR System Altitude Source

Here the altitude data source for a connected XPDR system can be selected to either be RS-232 or data bus. The default value for this parameter is *DATA BUS*.

For VT-01 Mode-S transponders, the parameter has to be set to *DATA BUS*.

To change the altitude source of a connected XPDR system, please carry out the following steps:

1. Open the menu with a long push on the **inner knob pushbutton**.
2. Use the **inner knob** to navigate to *XPDR SYSTEM* → *INSTALLATION* → *MAINTENANCE* → *XPDR CONFIG* → *ALT SOURCE*.
3. Use the **inner knob** to select a source.
4. Push the **inner knob pushbutton** to execute your selection.
5. Push the **ESC softkey** to leave the menu.

XPDR System Altitude Resolution

Here the resolution of transmitted altitude data to/from a connected XPDR system can be selected to either be 25ft or 100ft. The default value for this parameter is *25ft*.

For VT-01 Mode-S transponders, the parameter has to be set to *25ft*.

To change the altitude resolution of the XPDR, please carry out the following steps:

1. Open the menu with a long push on the **inner knob pushbutton**.
2. Use the **inner knob** to navigate to *XPDR SYSTEM* → *INSTALLATION* → *XPDR CONFIG* → *MAINTENANCE* → *ALT RESOLUTION*.
3. Use the **inner knob** to select a value.
4. Push the **inner knob pushbutton** to execute your selection.
5. Push the **ESC softkey** to leave the menu.

7.1 Interface Checkout

7.1.1 Data Bus Checks

In order to test data bus integrity and bus load, a pragmatic function test of ACD-57 connected to a second bus node can be performed. The second node may be another ACD-57 or any other compatible device, for example an aircraft radio or radar beacon system. After at least 20 minutes of continuous operation, check data validity and correct function by checking and verifying that no errors are detected.

We recommend the use of professional CAN BUS / CANaerospace analysis tools to check data bus integrity.

7.1.2 Serial Interface Check

The serial data interface of the unit can be checked with a pragmatic function test.

1. Connect ACD-57 and another compatible avionics system via a serial data port.
2. Verify correct operation.

7.2 Serial Control Interface Check

Verify that the connected device can control the ACD-57 as expected, that the ACD-57 can control the connected device as expected (e.g. QNH synchronisation), and that all data displayed on the ACD-57 and the connected device are correct and in sync.

7.3 COM Check

To check for correct COM functionality, use checkout procedures of the connected VHF transceiver.

7.4 XPDR Check

To check for correct XPDR functionality, use checkout procedures of the connected MODE-S transponder.

7.5 Altimeter Check

For altimeter checkout, use only aircraft manufacturer approved checkout procedures.

7.6 Lighting and Controls Check

7.6.1 Lighting Bus Check

The display and bezel key backlight on ACD-57 can track an external lighting bus input and use it to vary the display and bezel key illumination levels accordingly.

Connection of the aircraft lighting bus to the incorrect input pins can cause damage. Always start this test with the lighting bus at the lowest setting, and slowly increase the brightness. If it is noticed that the lighting level on the display does not increase as the lighting bus input is increased in brightness, verify that the wiring is correct before proceeding.

This check verifies that the interface is connected correctly.

1. Ensure the lighting bus is set to its minimum setting.
2. Slowly vary the lighting bus level that is connected to ACD-57. Verify that the display brightness tracks the lighting bus setting. Continue to maximum brightness and verify proper operation.

7.6.2 Light Sensor Check

The light sensor can sense ambient lighting conditions and adjust illumination of display and bezel keys accordingly.

This check verifies that the sensor is working correctly.

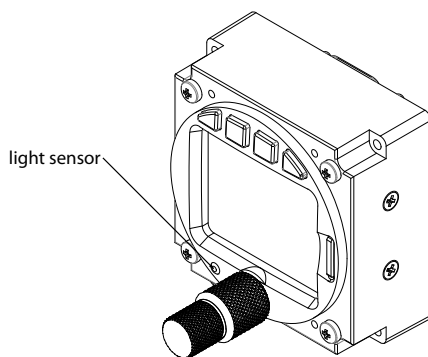

Figure 7.1.: Light sensor on the front bezel

1. Ensure that ILLUMINATION is set to AUTO.
2. Cover the light sensor with your finger and see if display and bezel illumination changes within a time of some seconds.

7.6.3 Controls Check

This check verifies that all controls operate correctly.

1. Manipulate all pilot controls (buttons 1,2,3,and 4), the concentric rotary knob, and the rotary knob pushbutton). Please consult the ACD-57 Pilot's Manual [1] for details on pilot controls.
2. Check if manipulation results in control input on the display.

Depending on the unit's configuration and software status not all controls may be active all the time.

7.6.4 Alert Sounder

This check verifies that the integrated alert sounder is working.

1. Set alert sounder volume. Test beeps shall be put out according to the volume settings.

7.7 Version / Revision Check

Verify that the currently installed software version/revision is approved and suitable for your device, aircraft, and configuration. Verify compatibility to all connected systems by cross-checking compatibility lists of all involved systems.

Software and hardware identification and version information can be reviewed directly on the display in *CONFIGURATION MENU* → *DEVICE* → *INFO*.

7.8 License Check

Check software licenses in *CONFIGURATION MENU* → *LICENSES*. Verify that the currently installed software licenses are suitable for your device, aircraft, and configuration. Ensure that all required functions are unlocked.

7.9 Failure Message Check

Check failure messages in *CONFIGURATION MENU* → *FAILURES*. Verify that no functions have failed and that no failure messages are visible.

8

Configuration and Checkout Documentation

8.1 Configuration Documentation

It is mandatory for each configuration that the configuration is logged in a document that is to be added to the aircraft records.

A configuration log form is provided in appendix H

8.2 Checkout Documentation

It is mandatory for each installation that the checkout is logged in a document that is to be added to the aircraft records.

A checkout log form is provided in appendix G

8.3 License Documentation

It is mandatory for each installation where function licenses are installed that installed licenses are logged in a document that is to be added to the aircraft records. It is required that all license codes are carefully noted in this log. If the device is repaired or reset to factory defaults, the code has to be re-entered. Customer license purchase history data is not saved. Therefore, if the code gets lost, the function license has to be purchased again at full cost to restore functionality.

A license log form is provided in appendix I

9.1 Software and Database Loading

Software upgrades and station databases are loaded using the integrated microSD card slot and a microSD memory card.

While the software is actually loaded onto the device, the station database remains on the microSD card. Therefore database information is only accessible if the microSD card is installed.

If the microSD card is not installed, not all functions will be available.

Never remove the microSD card while the device is in operation. If the microSD card is removed from the device during runtime, the device's software may stop working. In this case a system restart would be required.

9.1.1 microSD Card Slot

A microSD card slot is located on the right side of the unit's front panel. A microSD memory card can be inserted and removed from the device.

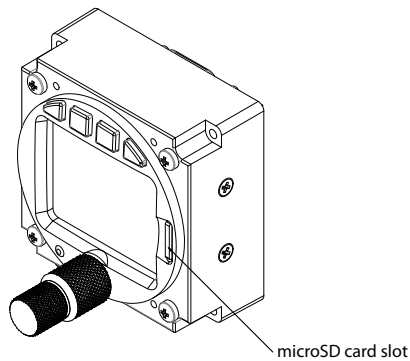

Figure 9.1.: microSD Card Slot

To insert a microSD card, insert the card into the slot, print facing to the display, little nose facing upwards and gently push the card until it clicks in.

Inserting the microSD card in the wrong orientation may damage the slot.

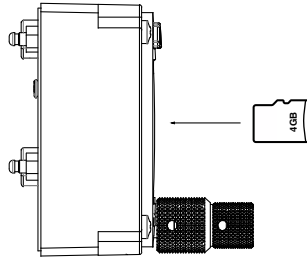

Figure 9.2.: microSD card in correct orientation

To remove an inserted microSD card, use your fingernail to gently push on the card until a click is audible. The card will be released following the click. Use your fingernail to remove the card.

Be careful. Application of too much force may damage the slot.

ACD-57 is compatible to all FAT or FAT32 formatted microSD cards. It has been successfully tested with microSD cards with a storage size of 2 to 64 gigabytes.

9.1.2 Using a Station Database

To use a database, please carry out the following steps:

1. Purchase a valid station database file in the *AIR Avionics License Store*. Please visit <https://www.air-avionics.com/license> for details.
2. Load the station database file onto a microSD card.
3. Insert the microSD card into the ACD-57.
4. Power the unit on.
5. Open the menu with a long push on the **inner knob pushbutton**.
6. Use the **inner knob** to navigate to *CONFIGURATION MENU* → *DEVICE* → *INFO* → *DATABASES*.
7. Verify correct installation in the databases list.
8. Push the **ESC softkey** to leave the menu.

When the database license expires, the database can no longer be used and database functions are no longer available.

The station database and related functions are only available while the microSD card

holding the station database file is inserted. If the microSD card is removed, the database and all related functions are unavailable.

9.1.3 Loading Software to ACD-57

In order to perform a software update, please carry out the following steps:

1. Load a valid ACD-57 firmware file onto a microSD card.
2. Insert the microSD card into the unit.
3. Power the unit on. An update message will appear.
4. Once the update process has been completed, verify the correct software version and function by reperforming all configuration, checkout, and documentation steps described in chapter 6, chapter 7, and chapter 8.
5. Update required documentation.

9.2 Cleaning

ACD-57 has a display that is coated with a special anti-reflective coating that is very sensitive to waxes and abrasive cleaners. It is very important to clean the display using a clean, lint-free cloth and an eyeglass lens cleaner that is specified as safe for anti-reflective coatings.

10.1 My unit says “No Info To Show”

As long as the device is not configured for a specific installation (factory default), the screen below appears.

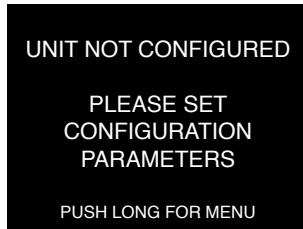

Figure 10.1.: Screen indicating factory state without configuration

In order to use ACD-57 the system has to be configured to its specific use case. It needs to know what it shall display (altimeter, XPDR, COM or any combination thereof) and it needs to know about the chosen installation options like type of COM/XPDR modules and their wiring. Please complete all the steps described in chapter 6 of this manual and try again.

10.2 Transponder shows error “0002000 CONNECTION” when switching to ALT mode

The connection between the Transponder and the ACD-57 is not working. This can be due to the following reasons:

- Cable not connected properly or transponder control settings not configured correctly. Please check wiring and verify that all parameters in *XPDR CONTROL* → *INSTALLATION* are correctly set.
- Transponder not supplied with power. Verify transponder power supply.
- CAN termination resistor not installed. Check if all termination resistors on both sides, i.e. on the transponder side and the other end of the databus are installed.

Please note: Some version of our cables B489, B490 and B554 between BECKER 62XX COM units and ACD-57 do not feature a built-in termination resistor.

[1] AIR Avionics, *ACD-57: Pilot's Manual*, rev 3.0, June 2021.

B

Assembly and Installation Drawings

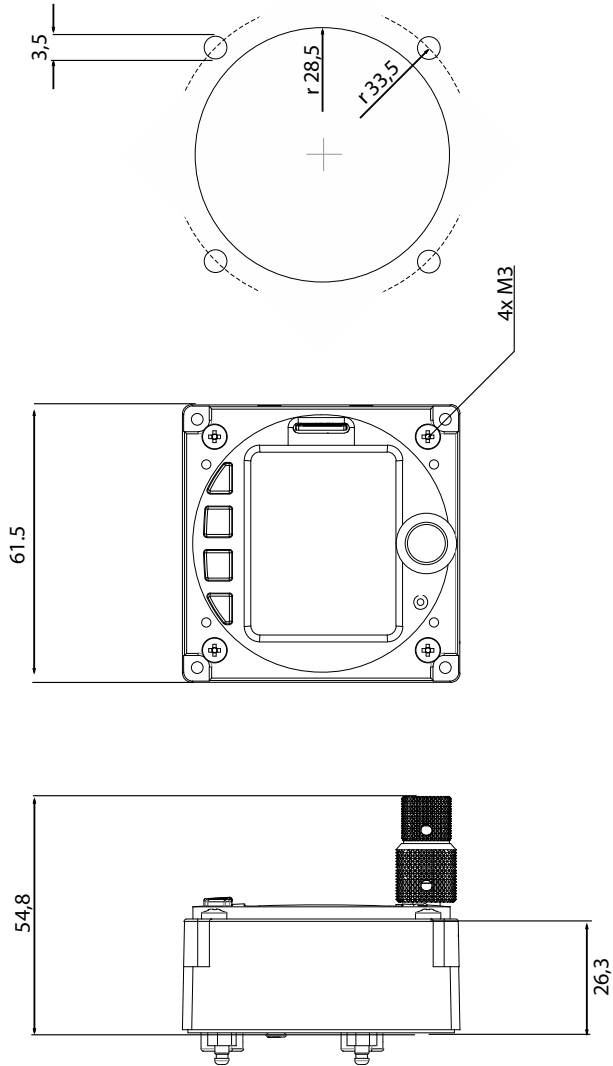
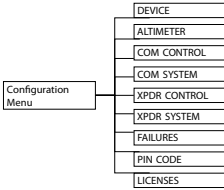

Figure B.1.: Dimensional drawing, all dimensions in millimeters

Configuration Menu Diagram



For better readability, the menu diagram is split into multiple separate parts on different pages of this manual.

This diagram shows the configuration menu levels required for installation. To view these menu levels, the pin code 3000 has to be entered in *CONFIGURATION MENU* → *PIN CODE*

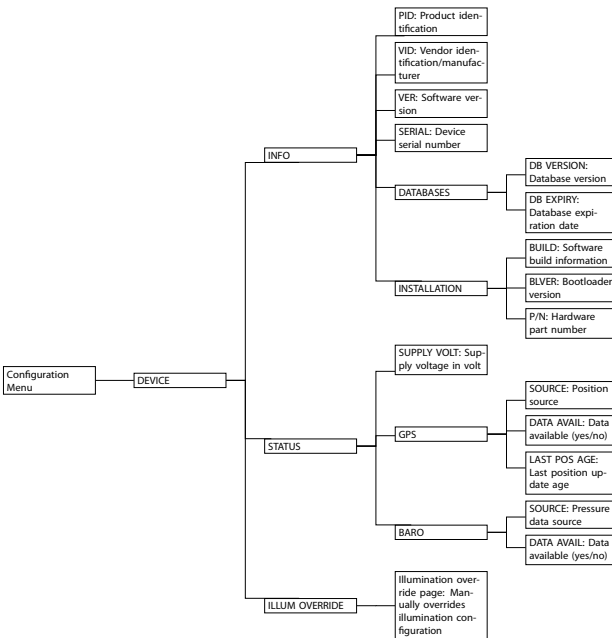

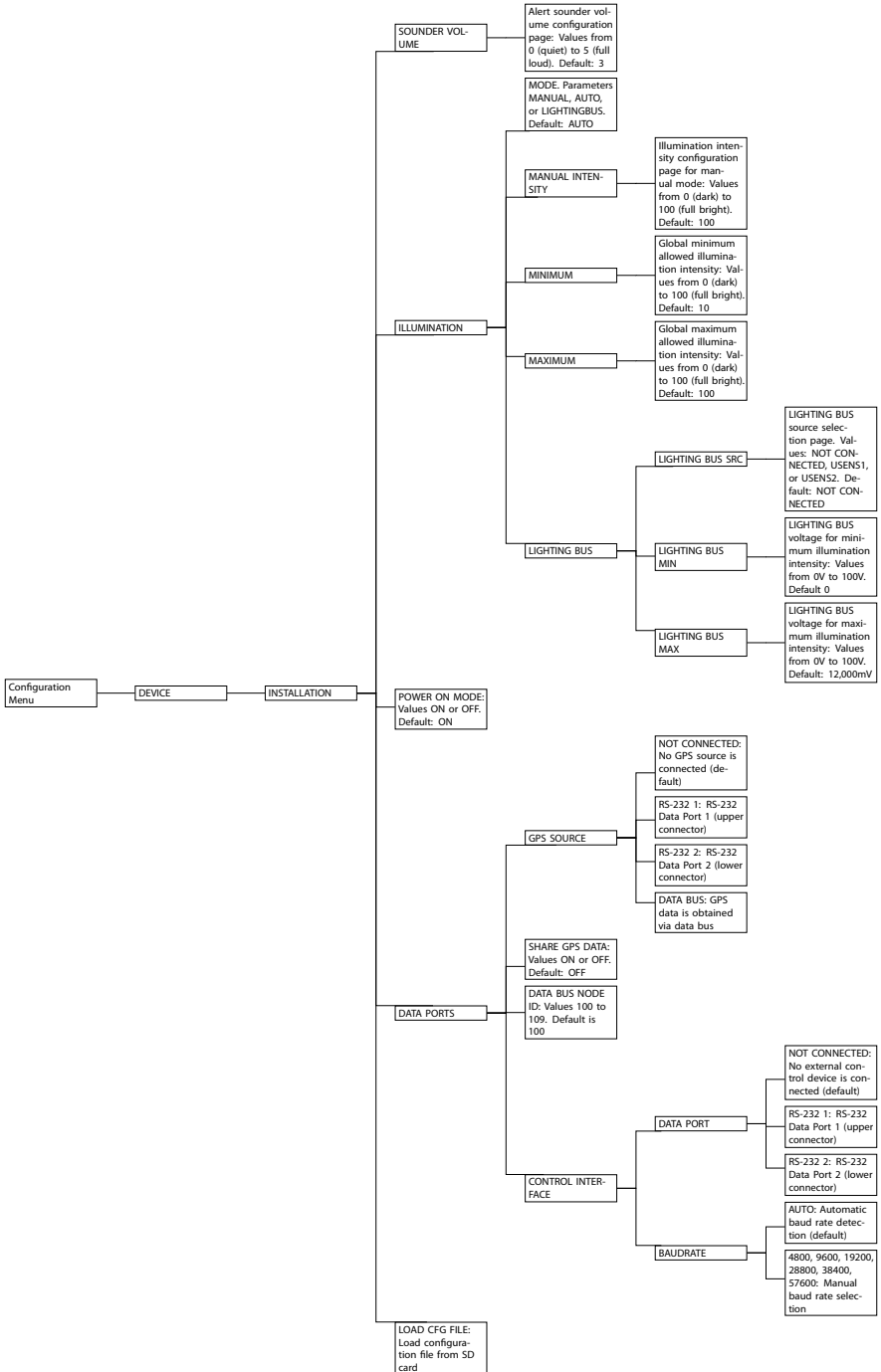

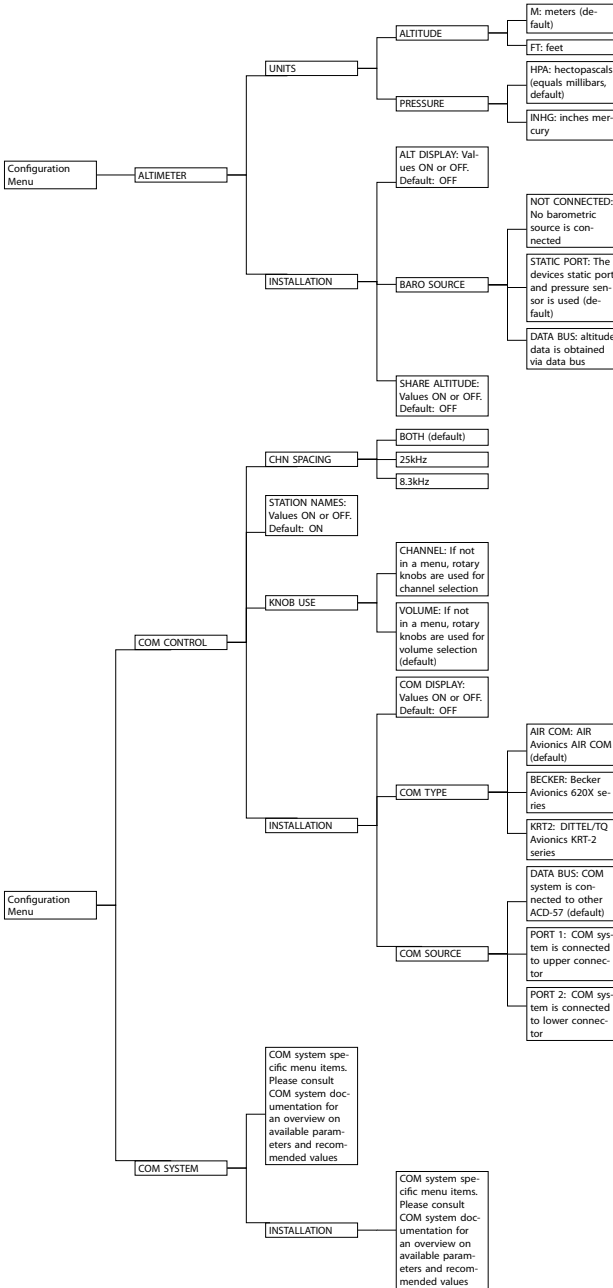

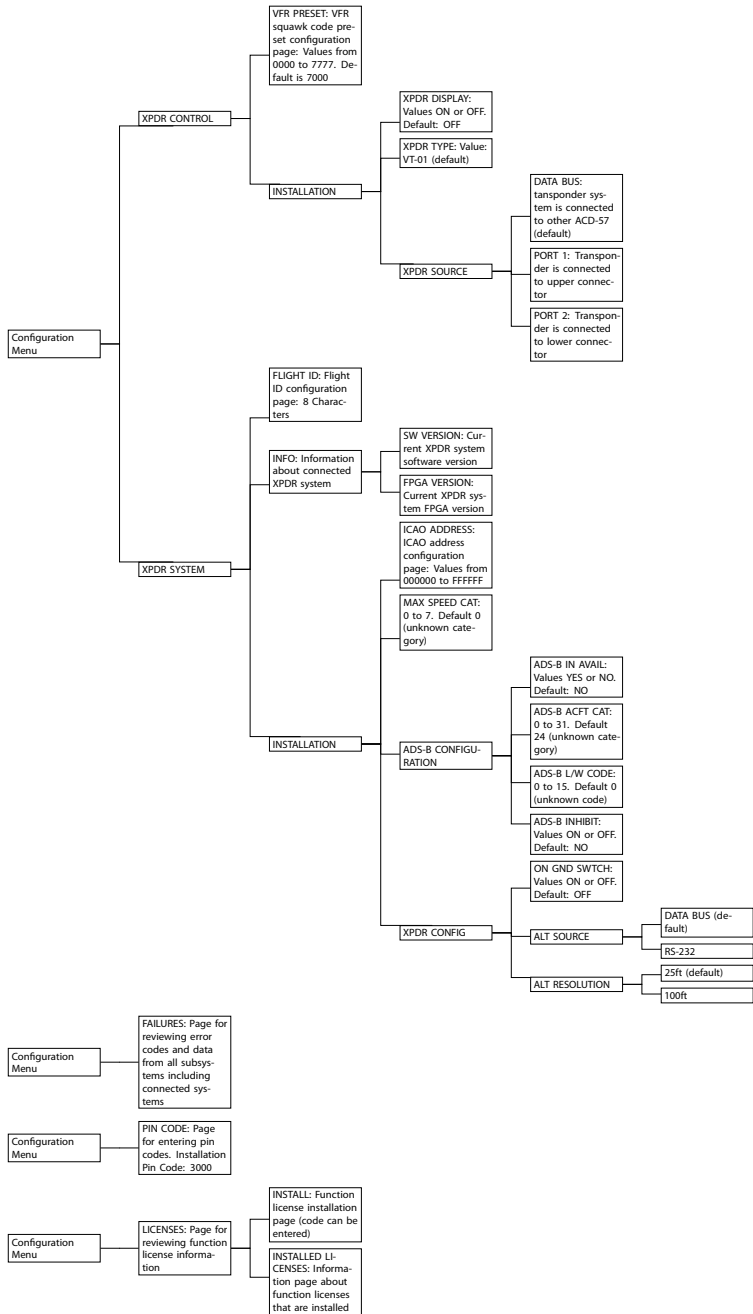

D.1 Display Only (Altimeter)

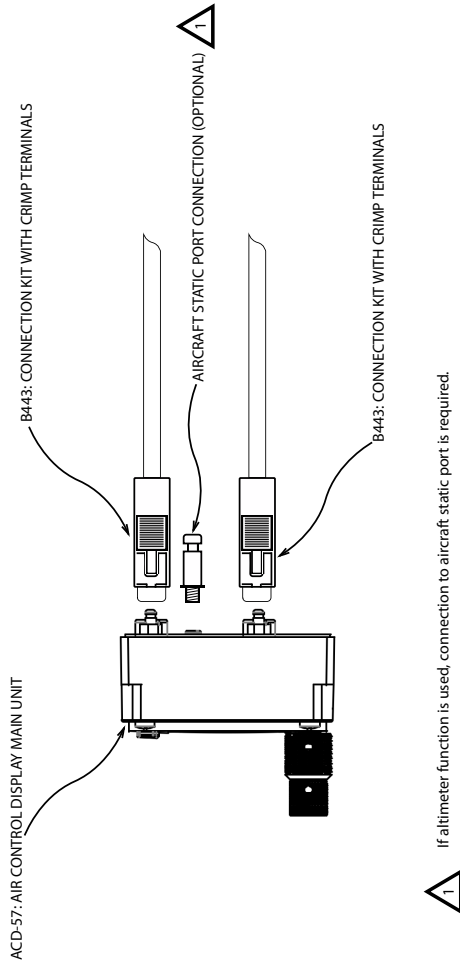

Figure D.1.: ACD-57 only (use as altimeter) with redundant power supply.

Configuration parameters recommended for ACD-57 in display only/altimeter configuration:

<i>Parameter</i>	<i>Recommended Value</i>
<i>DEVICE → INSTALLATION → SOUNDER VOLUME</i>	as required
<i>DEVICE → INSTALLATION → ILLUMINATION</i>	as required
<i>DEVICE → INSTALLATION → POWER ON MODE</i>	as required
<i>DEVICE → INSTALLATION → DATA PORTS → GPS SOURCE</i>	not relevant
<i>DEVICE → INSTALLATION → DATA PORTS → SHARE GPS DATA</i>	not relevant
<i>DEVICE → INSTALLATION → DATA PORTS → DATA BUS NODE ID</i>	100
<i>ALTIMETER → UNITS</i>	as required
<i>ALTIMETER → INSTALLATION → ALT DISPLAY</i>	ON
<i>ALTIMETER → INSTALLATION → BARO SOURCE</i>	STATIC PORT
<i>ALTIMETER → INSTALLATION → SHARE ALTITUDE</i>	OFF
<i>COM CONTROL → CHN SPACING</i>	not relevant
<i>COM CONTROL → STATION NAMES</i>	not relevant
<i>COM CONTROL → KNOB USE</i>	not relevant
<i>COM CONTROL → INSTALLATION → COM DISPLAY</i>	OFF
<i>COM CONTROL → INSTALLATION → COM TYPE</i>	not relevant
<i>COM CONTROL → INSTALLATION → COM SOURCE</i>	not relevant
<i>COM SYSTEM</i>	not relevant
<i>XPDR CONTROL → VFR PRESET</i>	not relevant
<i>XPDR CONTROL → INSTALLATION → XPDR DISPLAY</i>	OFF
<i>XPDR CONTROL → INSTALLATION → XPDR TYPE</i>	not relevant
<i>XPDR CONTROL → INSTALLATION → XPDR SOURCE</i>	not relevant
<i>XPDR SYSTEM</i>	not relevant
<i>LICENSES</i>	Altimeter license must be installed!

D.2 ACD-57 and AIR COM VHF Transceiver

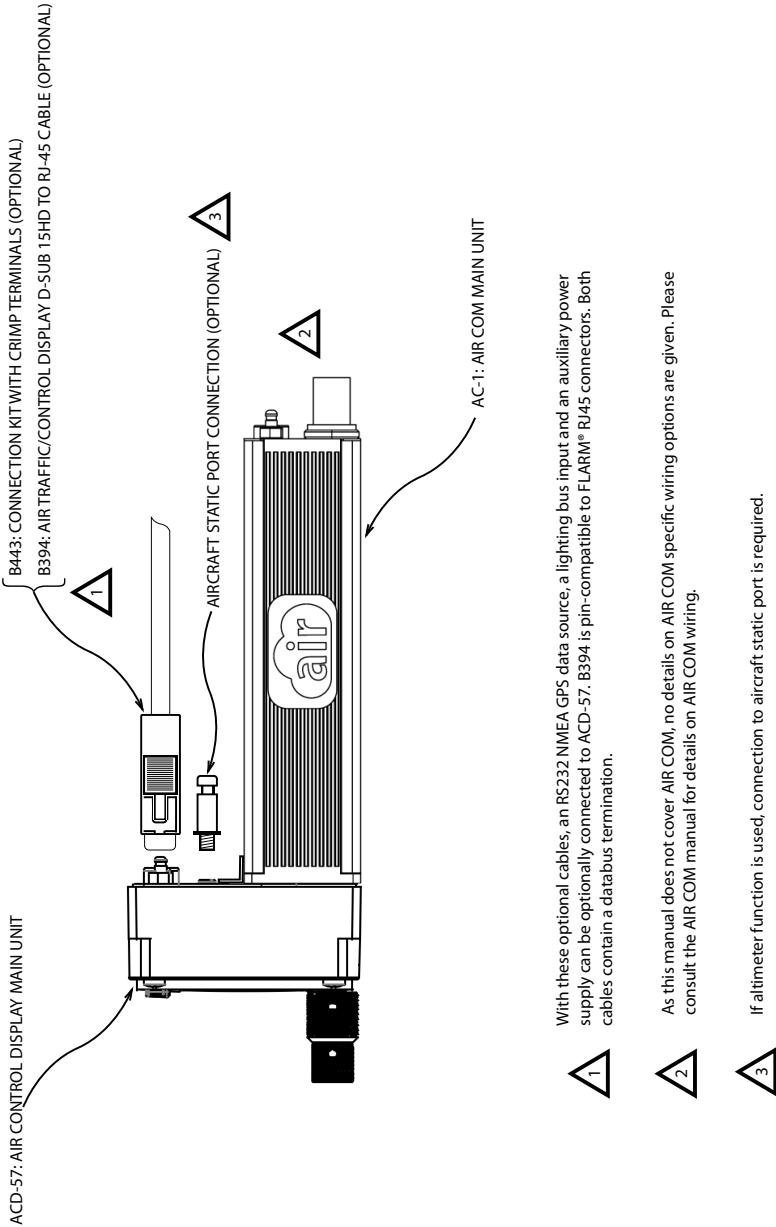

Figure D.2.: ACD-57 and AIR COM directly connected

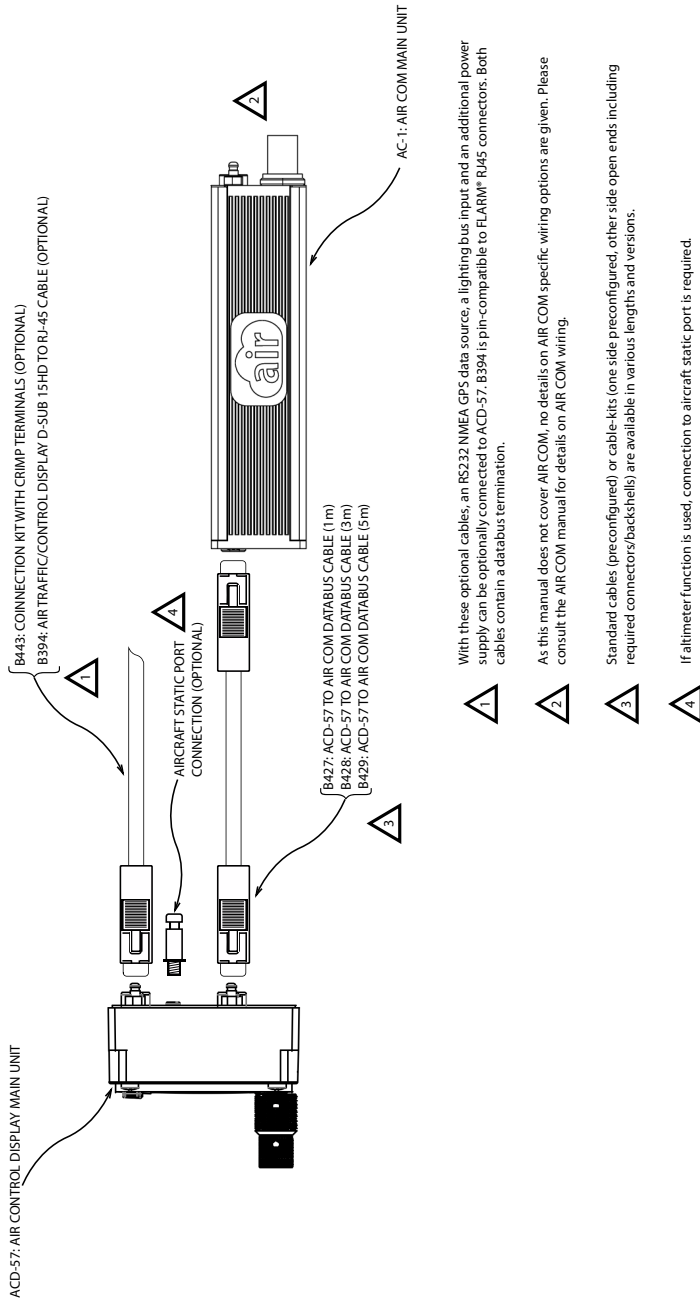

Figure D.3.: ACD-57 and AIR COM connected with cable

Configuration parameters recommended for ACD-57 and AIR COM:

<i>Parameter</i>	<i>Recommended Value</i>
<i>DEVICE → INSTALLATION → SOUNDER VOLUME</i>	as required
<i>DEVICE → INSTALLATION → ILLUMINATION</i>	as required
<i>DEVICE → INSTALLATION → POWER ON MODE</i>	as required
<i>DEVICE → INSTALLATION → DATA PORTS → GPS SOURCE</i>	as required, if GPS is connected to upper port, set to RS-232 1
<i>DEVICE → INSTALLATION → DATA PORTS → SHARE GPS DATA</i>	OFF
<i>DEVICE → INSTALLATION → DATA PORTS → DATA BUS NODE ID</i>	100
<i>ALTIMETER → UNITS</i>	as required
<i>ALTIMETER → INSTALLATION → ALT DISPLAY</i>	as required, if altimeter is used, set to ON
<i>ALTIMETER → INSTALLATION → BARO SOURCE</i>	as required, if altimeter is used, set to STATIC PORT
<i>ALTIMETER → INSTALLATION → SHARE ALTITUDE</i>	OFF
<i>COM CONTROL → CHN SPACING</i>	as required
<i>COM CONTROL → STATION NAMES</i>	as required
<i>COM CONTROL → KNOB USE</i>	as required
<i>COM CONTROL → INSTALLATION → COM DISPLAY</i>	ON
<i>COM CONTROL → INSTALLATION → COM TYPE</i>	AIR COM
<i>COM CONTROL → INSTALLATION → COM SOURCE</i>	PORT 2
<i>COM SYSTEM</i>	as required
<i>XPDR CONTROL → VFR PRESET</i>	not relevant
<i>XPDR CONTROL → INSTALLATION → XPDR DISPLAY</i>	OFF
<i>XPDR CONTROL → INSTALLATION → XPDR TYPE</i>	not relevant
<i>XPDR CONTROL → INSTALLATION → XPDR SOURCE</i>	not relevant
<i>XPDR SYSTEM</i>	not relevant
<i>LICENSES</i>	if altimeter used, altimeter license is required

D.3 Dual ACD-57 and AIR COM VHF Transceiver

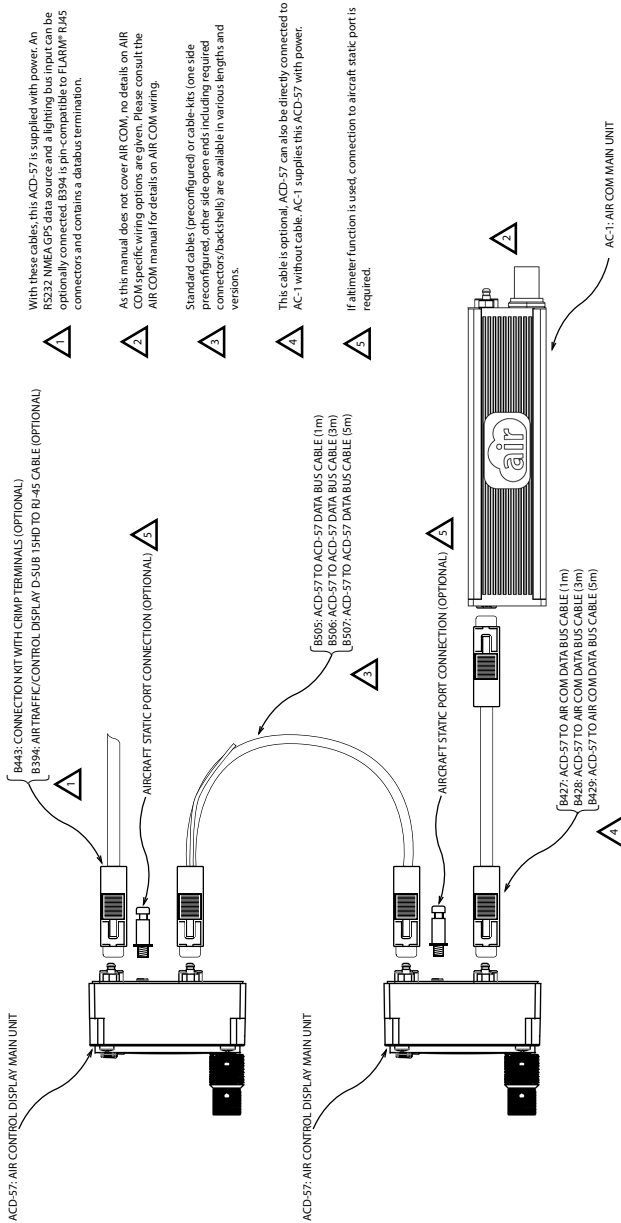

Figure D.4.: Dual ACD-57 and AIR COM connected with cable

Parameters for first ACD-57 (the left/upper one in the diagram):

<i>Parameter</i>	<i>Recommended Value</i>
<i>DEVICE → INSTALLATION → SOUNDER VOLUME</i>	as required
<i>DEVICE → INSTALLATION → ILLUMINATION</i>	as required
<i>DEVICE → INSTALLATION → POWER ON MODE</i>	as required
<i>DEVICE → INSTALLATION → DATA PORTS → GPS SOURCE</i>	as required, if GPS is connected to upper port, set to RS-232 1
<i>DEVICE → INSTALLATION → DATA PORTS → SHARE GPS DATA</i>	as required, if GPS is used, set to ON
<i>DEVICE → INSTALLATION → DATA PORTS → DATA BUS NODE ID</i>	100
<i>ALTIMETER → UNITS</i>	as required
<i>ALTIMETER → INSTALLATION → ALT DISPLAY</i>	as required, if altimeter is used, set to ON
<i>ALTIMETER → INSTALLATION → BARO SOURCE</i>	as required, if altimeter is used, set to STATIC PORT
<i>ALTIMETER → INSTALLATION → SHARE ALTITUDE</i>	as required, if altimeter is used, set to ON
<i>COM CONTROL → CHN SPACING</i>	as required
<i>COM CONTROL → STATION NAMES</i>	as required
<i>COM CONTROL → KNOB USE</i>	as required
<i>COM CONTROL → INSTALLATION → COM DISPLAY</i>	ON
<i>COM CONTROL → INSTALLATION → COM TYPE</i>	AIR COM
<i>COM CONTROL → INSTALLATION → COM SOURCE</i>	DATA BUS
<i>COM SYSTEM</i>	as required
<i>XPDR CONTROL → VFR PRESET</i>	not relevant
<i>XPDR CONTROL → INSTALLATION → XPDR DISPLAY</i>	OFF
<i>XPDR CONTROL → INSTALLATION → XPDR TYPE</i>	not relevant
<i>XPDR CONTROL → INSTALLATION → XPDR SOURCE</i>	not relevant
<i>XPDR SYSTEM</i>	not relevant
<i>LICENSES</i>	if altimeter used, altimeter license is required

Parameters for second ACD-57 (the right/lower one in the diagram with the connected AIR COM):

<i>Parameter</i>	<i>Recommended Value</i>
<i>DEVICE → INSTALLATION → SOUNDER VOLUME</i>	as required
<i>DEVICE → INSTALLATION → ILLUMINATION</i>	as required
<i>DEVICE → INSTALLATION → POWER ON MODE</i>	as required
<i>DEVICE → INSTALLATION → DATA PORTS → GPS SOURCE</i>	as required, if GPS is connected to other ACD-57 (above), set to DATA BUS
<i>DEVICE → INSTALLATION → DATA PORTS → SHARE GPS DATA</i>	OFF
<i>DEVICE → INSTALLATION → DATA PORTS → DATA BUS NODE ID</i>	101
<i>ALTIMETER → UNITS</i>	as required
<i>ALTIMETER → INSTALLATION → ALT DISPLAY</i>	as required, if altimeter is used, set to ON
<i>ALTIMETER → INSTALLATION → BARO SOURCE</i>	as required, if altimeter is used, set to STATIC PORT
<i>ALTIMETER → INSTALLATION → SHARE ALTITUDE</i>	OFF
<i>COM CONTROL → CHN SPACING</i>	as required
<i>COM CONTROL → STATION NAMES</i>	as required
<i>COM CONTROL → KNOB USE</i>	as required
<i>COM CONTROL → INSTALLATION → COM DISPLAY</i>	ON
<i>COM CONTROL → INSTALLATION → COM TYPE</i>	AIR COM
<i>COM CONTROL → INSTALLATION → COM SOURCE</i>	PORT 2
<i>COM SYSTEM</i>	as required
<i>XPDR CONTROL → VFR PRESET</i>	not relevant
<i>XPDR CONTROL → INSTALLATION → XPDR DISPLAY</i>	OFF
<i>XPDR CONTROL → INSTALLATION → XPDR TYPE</i>	not relevant
<i>XPDR CONTROL → INSTALLATION → XPDR SOURCE</i>	not relevant
<i>XPDR SYSTEM</i>	not relevant
<i>LICENSES</i>	if altimeter used, altimeter license is required

D.4 ACD-57 and Becker 620X or TRIG TY91/92 VHF Transceiver

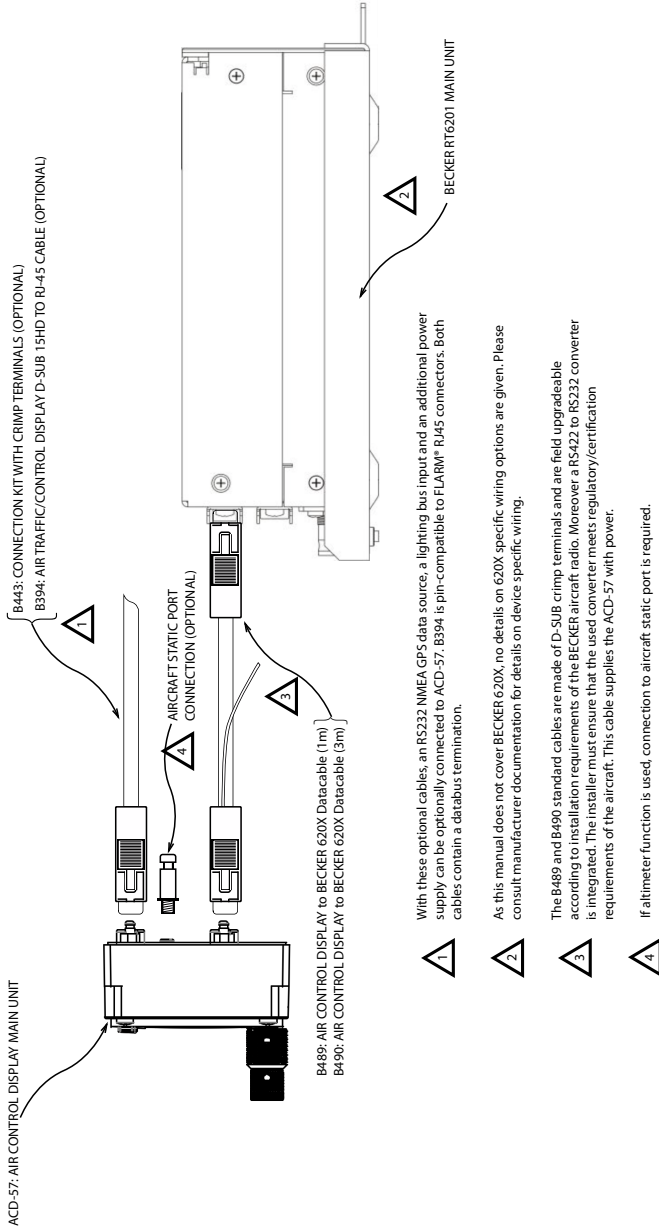

Figure D.5.: ACD-57 and Becker 620X connected with cable

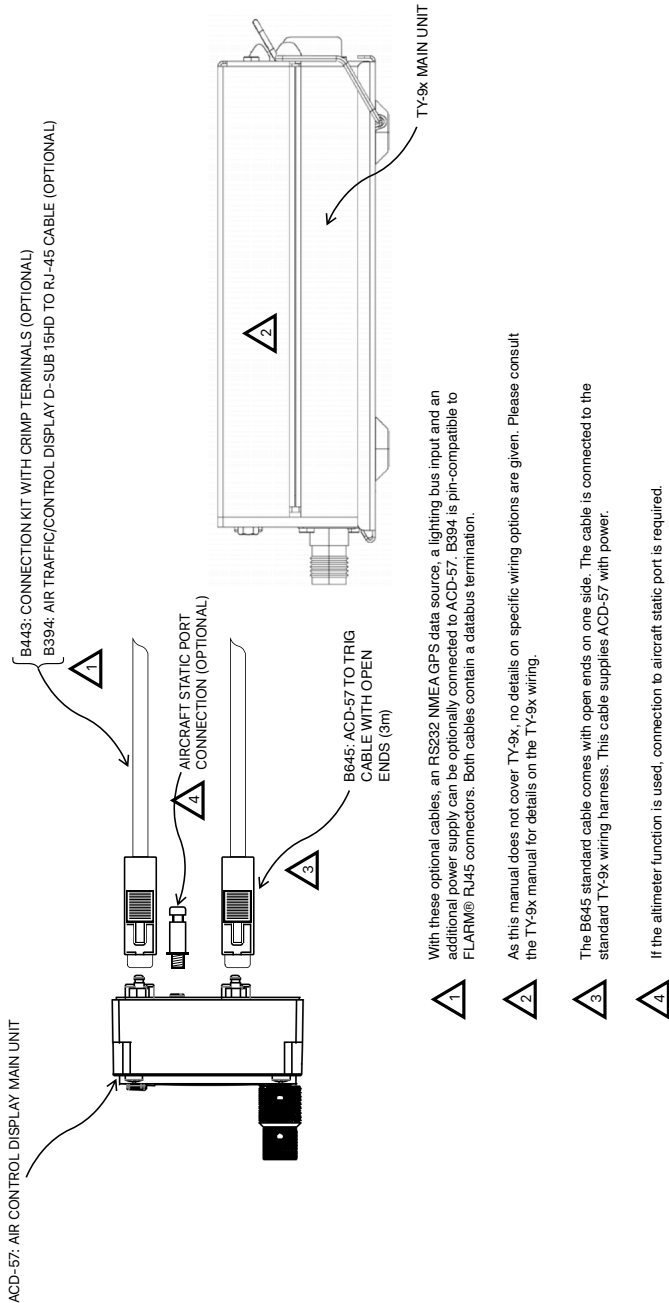

Figure D.6.: ACD-57 and TRIG TY91/92 connected with cable

Configuration parameters recommended for ACD-57 and Becker 620X / TRIG TY91/92:

<i>Parameter</i>	<i>Recommended Value</i>
<i>DEVICE → INSTALLATION → SOUNDER VOLUME</i>	as required
<i>DEVICE → INSTALLATION → ILLUMINATION</i>	as required
<i>DEVICE → INSTALLATION → POWER ON MODE</i>	as required
<i>DEVICE → INSTALLATION → DATA PORTS → GPS SOURCE</i>	as required, if GPS is connected to upper port, set to RS-232 1
<i>DEVICE → INSTALLATION → DATA PORTS → SHARE GPS DATA</i>	OFF
<i>DEVICE → INSTALLATION → DATA PORTS → DATA BUS NODE ID</i>	100
<i>ALTIMETER → UNITS</i>	as required
<i>ALTIMETER → INSTALLATION → ALT DISPLAY</i>	as required, if altimeter is used, set to ON
<i>ALTIMETER → INSTALLATION → BARO SOURCE</i>	as required, if altimeter is used, set to STATIC PORT
<i>ALTIMETER → INSTALLATION → SHARE ALTITUDE</i>	OFF
<i>COM CONTROL → CHN SPACING</i>	as required
<i>COM CONTROL → STATION NAMES</i>	as required
<i>COM CONTROL → KNOB USE</i>	as required
<i>COM CONTROL → INSTALLATION → COM DISPLAY</i>	ON
<i>COM CONTROL → INSTALLATION → COM TYPE</i>	BECKER or TRIG TY
<i>COM CONTROL → INSTALLATION → COM SOURCE</i>	PORT 2
<i>COM SYSTEM</i>	as required
<i>XPDR CONTROL → VFR PRESET</i>	not relevant
<i>XPDR CONTROL → INSTALLATION → XPDR DISPLAY</i>	OFF
<i>XPDR CONTROL → INSTALLATION → XPDR TYPE</i>	not relevant
<i>XPDR CONTROL → INSTALLATION → XPDR SOURCE</i>	not relevant
<i>XPDR SYSTEM</i>	not relevant
<i>LICENSES</i>	if altimeter used, altimeter license is required
<i>LICENSES</i>	Becker or TRIG TY license

D.5 Dual ACD-57 and Becker 620X / TRIG TY91/92: Transceiver

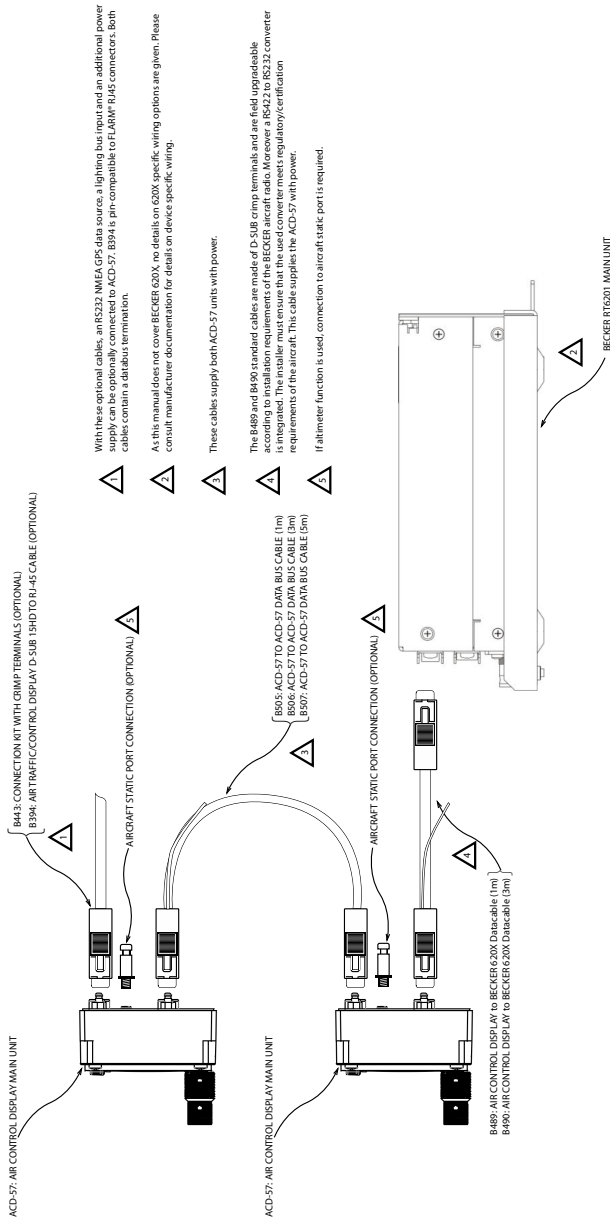
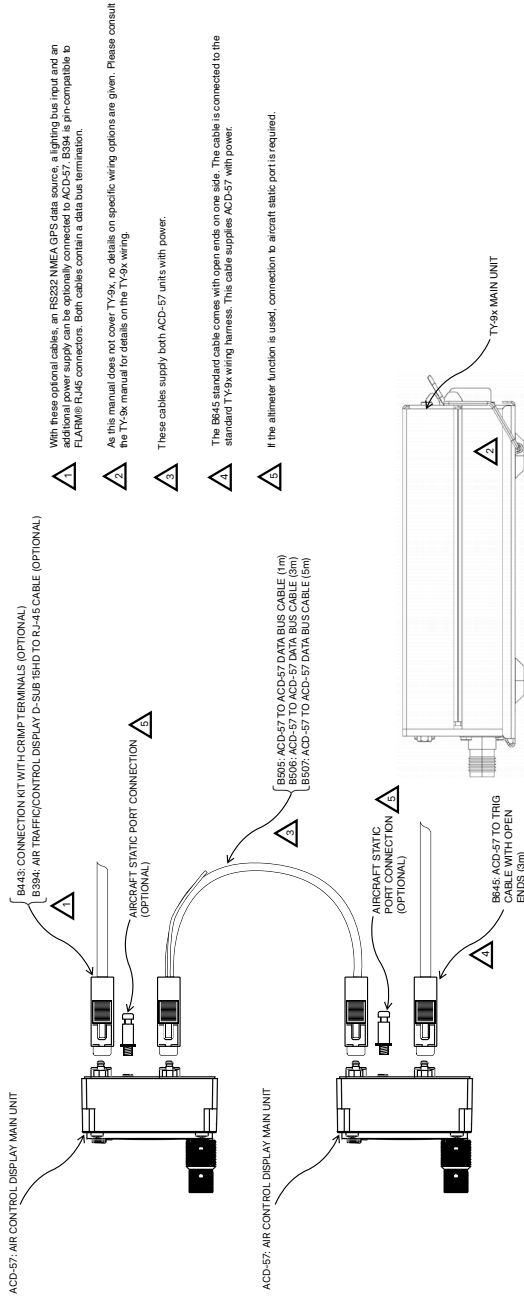

Figure D.7.: Dual ACD-57 and Becker 620X connected with cables



- A** With these optional cables, an RS232 NMEA GPS data source, a lighting bus input and an alternate power supply can be optionally connected to ACD-57. B8394 is pin-compatible to FURRite RJ45 connectors. Both cables contain a data bus termination.
- B** As this manual does not cover TY9x, no details on specific wiring options are given. Please consult the TY-9x manual for details on the TY-9x wiring.
- C** These cables supply both ACD-57 units with power.
- A** The B845 standard cable comes with open ends on one side. The cable is connected to the standard TY-9x wiring harness. This cable supplies ACD-57 with power.
- B** If the alternate function is used, connection to aircraft static port is required.

Figure D.8.: Dual ACD-57 and TRIG TY91/92 connected with cables

Parameters for first ACD-57 (the left/upper one in the diagram):

<i>Parameter</i>	<i>Recommended Value</i>
<i>DEVICE → INSTALLATION → SOUNDER VOLUME</i>	as required
<i>DEVICE → INSTALLATION → ILLUMINATION</i>	as required
<i>DEVICE → INSTALLATION → POWER ON MODE</i>	as required
<i>DEVICE → INSTALLATION → DATA PORTS → GPS SOURCE</i>	as required, if GPS is connected to upper port, set to RS-232 1
<i>DEVICE → INSTALLATION → DATA PORTS → SHARE GPS DATA</i>	as required, if GPS is used, set to ON
<i>DEVICE → INSTALLATION → DATA PORTS → DATA BUS NODE ID</i>	100
<i>ALTIMETER → UNITS</i>	as required
<i>ALTIMETER → INSTALLATION → ALT DISPLAY</i>	as required, if altimeter is used, set to ON
<i>ALTIMETER → INSTALLATION → BARO SOURCE</i>	as required, if altimeter is used, set to STATIC PORT
<i>ALTIMETER → INSTALLATION → SHARE ALTITUDE</i>	as required, if altimeter is used, set to ON
<i>COM CONTROL → CHN SPACING</i>	as required
<i>COM CONTROL → STATION NAMES</i>	as required
<i>COM CONTROL → KNOB USE</i>	as required
<i>COM CONTROL → INSTALLATION → COM DISPLAY</i>	ON
<i>COM CONTROL → INSTALLATION → COM TYPE</i>	BECKER / TRIG TY
<i>COM CONTROL → INSTALLATION → COM SOURCE</i>	DATA BUS
<i>(COM SYSTEM not available)</i>	(not available)
<i>XPDR CONTROL → VFR PRESET</i>	not relevant
<i>XPDR CONTROL → INSTALLATION → XPDR DISPLAY</i>	OFF
<i>XPDR CONTROL → INSTALLATION → XPDR TYPE</i>	not relevant
<i>XPDR CONTROL → INSTALLATION → XPDR SOURCE</i>	not relevant
<i>XPDR SYSTEM</i>	not relevant
<i>LICENSES</i>	if altimeter used, altimeter license is required

Parameters for second ACD-57 (the right/lower one in the diagram with the connected Becker 620X):

<i>Parameter</i>	<i>Recommended Value</i>
<i>DEVICE → INSTALLATION → SOUNDER VOLUME</i>	as required
<i>DEVICE → INSTALLATION → ILLUMINATION</i>	as required
<i>DEVICE → INSTALLATION → POWER ON MODE</i>	as required
<i>DEVICE → INSTALLATION → DATA PORTS → GPS SOURCE</i>	as required, if GPS is connected to other ACD-57, set to DATA BUS
<i>DEVICE → INSTALLATION → DATA PORTS → SHARE GPS DATA</i>	OFF
<i>DEVICE → INSTALLATION → DATA PORTS → DATA BUS NODE ID</i>	101
<i>ALTIMETER → UNITS</i>	as required
<i>ALTIMETER → INSTALLATION → ALT DISPLAY</i>	as required, if altimeter is used, set to ON
<i>ALTIMETER → INSTALLATION → BARO SOURCE</i>	as required, if altimeter is used, set to STATIC PORT
<i>ALTIMETER → INSTALLATION → SHARE ALTITUDE</i>	OFF
<i>COM CONTROL → CHN SPACING</i>	as required
<i>COM CONTROL → STATION NAMES</i>	as required
<i>COM CONTROL → KNOB USE</i>	as required
<i>COM CONTROL → INSTALLATION → COM DISPLAY</i>	ON
<i>COM CONTROL → INSTALLATION → COM TYPE</i>	BECKER / TRIG TY
<i>COM CONTROL → INSTALLATION → COM SOURCE</i>	PORT 2
<i>COM SYSTEM</i>	as required
<i>XPDR CONTROL → VFR PRESET</i>	not relevant
<i>XPDR CONTROL → INSTALLATION → XPDR DISPLAY</i>	OFF
<i>XPDR CONTROL → INSTALLATION → XPDR TYPE</i>	not relevant
<i>XPDR CONTROL → INSTALLATION → XPDR SOURCE</i>	not relevant
<i>XPDR SYSTEM</i>	not relevant
<i>LICENSES</i>	if altimeter used, altimeter license is required
<i>LICENSES</i>	Becker or TRIG license

D.6 ACD-57 and Dittel/TQ KRT-2 VHF Transceiver

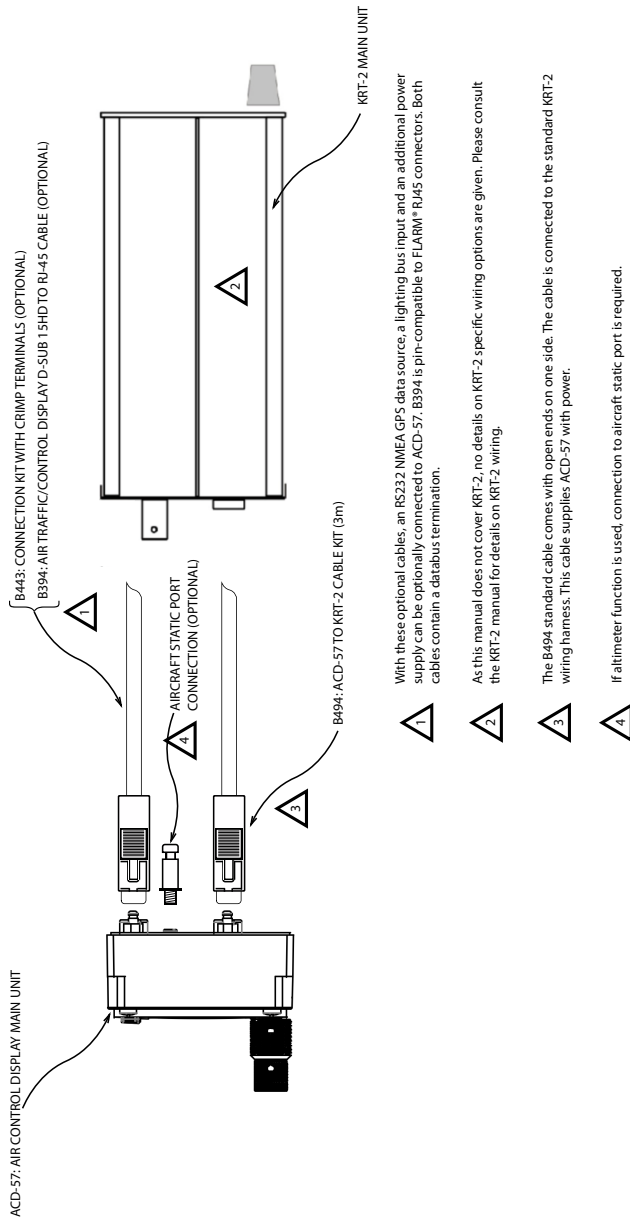

Figure D.9.: ACD-57 and Dittel KRT-2 connected with cable

Configuration parameters recommended for ACD-57 and Dittel/TQ KRT-2:

<i>Parameter</i>	<i>Recommended Value</i>
<i>DEVICE → INSTALLATION → SOUNDER VOLUME</i>	as required
<i>DEVICE → INSTALLATION → ILLUMINATION</i>	as required
<i>DEVICE → INSTALLATION → POWER ON MODE</i>	as required
<i>DEVICE → INSTALLATION → DATA PORTS → GPS SOURCE</i>	as required, if GPS is connected to upper port, set to RS-232 1
<i>DEVICE → INSTALLATION → DATA PORTS → SHARE GPS DATA</i>	OFF
<i>DEVICE → INSTALLATION → DATA PORTS → DATA BUS NODE ID</i>	100
<i>ALTIMETER → UNITS</i>	as required
<i>ALTIMETER → INSTALLATION → ALT DISPLAY</i>	as required, if altimeter is used, set to ON
<i>ALTIMETER → INSTALLATION → BARO SOURCE</i>	as required, if altimeter is used, set to STATIC PORT
<i>ALTIMETER → INSTALLATION → SHARE ALTITUDE</i>	OFF
<i>COM CONTROL → CHN SPACING</i>	as required
<i>COM CONTROL → STATION NAMES</i>	as required
<i>COM CONTROL → KNOB USE</i>	as required
<i>COM CONTROL → INSTALLATION → COM DISPLAY</i>	ON
<i>COM CONTROL → INSTALLATION → COM TYPE</i>	KRT2
<i>COM CONTROL → INSTALLATION → COM SOURCE</i>	PORT 2
<i>COM SYSTEM</i>	as required
<i>XPDR CONTROL → VFR PRESET</i>	not relevant
<i>XPDR CONTROL → INSTALLATION → XPDR DISPLAY</i>	OFF
<i>XPDR CONTROL → INSTALLATION → XPDR TYPE</i>	not relevant
<i>XPDR CONTROL → INSTALLATION → XPDR SOURCE</i>	not relevant
<i>XPDR SYSTEM</i>	not relevant
<i>LICENSES</i>	if altimeter used, altimeter license is required

D.7 Dual ACD-57 and Dittel/TQ KRT-2 VHF Transceiver

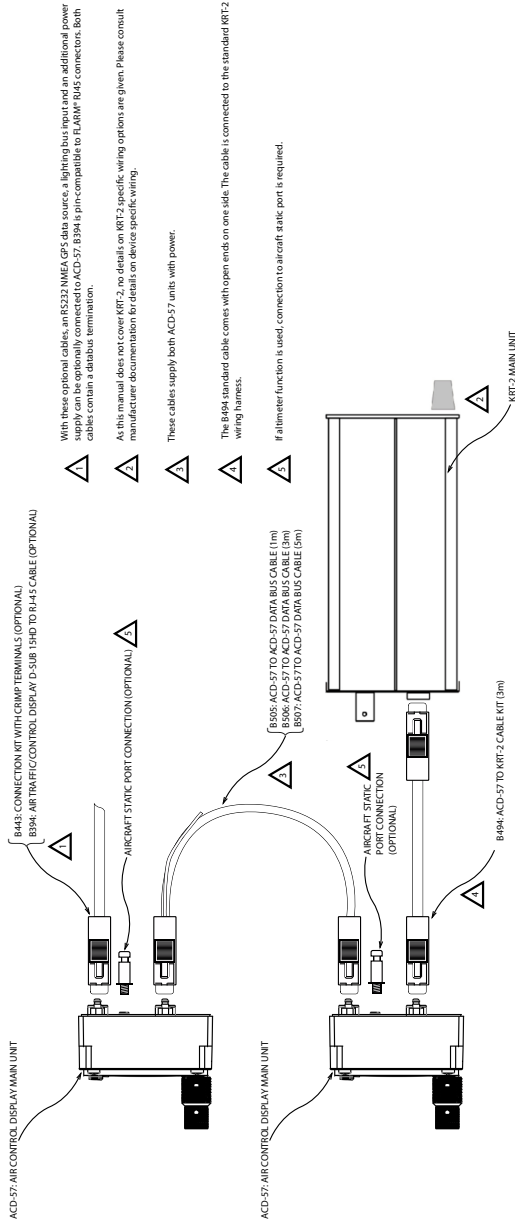

Figure D.10.: Dual ACD-57 and Dittel/TQ KRT-2 connected with cables

Parameters for first ACD-57 (the left/upper one in the diagram):

<i>Parameter</i>	<i>Recommended Value</i>
<i>DEVICE → INSTALLATION → SOUNDER VOLUME</i>	as required
<i>DEVICE → INSTALLATION → ILLUMINATION</i>	as required
<i>DEVICE → INSTALLATION → POWER ON MODE</i>	as required
<i>DEVICE → INSTALLATION → DATA PORTS → GPS SOURCE</i>	as required, if GPS is connected to upper port, set to RS-232 1
<i>DEVICE → INSTALLATION → DATA PORTS → SHARE GPS DATA</i>	as required, if GPS is used, set to ON
<i>DEVICE → INSTALLATION → DATA PORTS → DATA BUS NODE ID</i>	100
<i>ALTIMETER → UNITS</i>	as required
<i>ALTIMETER → INSTALLATION → ALT DISPLAY</i>	as required, if altimeter is used, set to ON
<i>ALTIMETER → INSTALLATION → BARO SOURCE</i>	as required, if altimeter is used, set to STATIC PORT
<i>ALTIMETER → INSTALLATION → SHARE ALTITUDE</i>	as required, if altimeter is used, set to ON
<i>COM CONTROL → CHN SPACING</i>	as required
<i>COM CONTROL → STATION NAMES</i>	as required
<i>COM CONTROL → KNOB USE</i>	as required
<i>COM CONTROL → INSTALLATION → COM DISPLAY</i>	ON
<i>COM CONTROL → INSTALLATION → COM TYPE</i>	KRT2
<i>COM CONTROL → INSTALLATION → COM SOURCE</i>	DATA BUS
<i>(COM SYSTEM not available)</i>	(not available)
<i>XPDR CONTROL → VFR PRESET</i>	not relevant
<i>XPDR CONTROL → INSTALLATION → XPDR DISPLAY</i>	OFF
<i>XPDR CONTROL → INSTALLATION → XPDR TYPE</i>	not relevant
<i>XPDR CONTROL → INSTALLATION → XPDR SOURCE</i>	not relevant
<i>XPDR SYSTEM</i>	not relevant
<i>LICENSES</i>	if altimeter used, altimeter license is required

Parameters for second ACD-57 (the right/lower one in the diagram with the connected KRT-2):

<i>Parameter</i>	<i>Recommended Value</i>
<i>DEVICE → INSTALLATION → SOUNDER VOLUME</i>	as required
<i>DEVICE → INSTALLATION → ILLUMINATION</i>	as required
<i>DEVICE → INSTALLATION → POWER ON MODE</i>	as required
<i>DEVICE → INSTALLATION → DATA PORTS → GPS SOURCE</i>	as required, if GPS is connected to other ACD-57, set to DATA BUS
<i>DEVICE → INSTALLATION → DATA PORTS → SHARE GPS DATA</i>	OFF
<i>DEVICE → INSTALLATION → DATA PORTS → DATA BUS NODE ID</i>	101
<i>ALTIMETER → UNITS</i>	as required
<i>ALTIMETER → INSTALLATION → ALT DISPLAY</i>	as required, if altimeter is used, set to ON
<i>ALTIMETER → INSTALLATION → BARO SOURCE</i>	as required, if altimeter is used, set to STATIC PORT
<i>ALTIMETER → INSTALLATION → SHARE ALTITUDE</i>	OFF
<i>COM CONTROL → CHN SPACING</i>	as required
<i>COM CONTROL → STATION NAMES</i>	as required
<i>COM CONTROL → KNOB USE</i>	as required
<i>COM CONTROL → INSTALLATION → COM DISPLAY</i>	ON
<i>COM CONTROL → INSTALLATION → COM TYPE</i>	KRT2
<i>COM CONTROL → INSTALLATION → COM SOURCE</i>	PORT 2
<i>COM SYSTEM</i>	as required
<i>XPDR CONTROL → VFR PRESET</i>	not relevant
<i>XPDR CONTROL → INSTALLATION → XPDR DISPLAY</i>	OFF
<i>XPDR CONTROL → INSTALLATION → XPDR TYPE</i>	not relevant
<i>XPDR CONTROL → INSTALLATION → XPDR SOURCE</i>	not relevant
<i>XPDR SYSTEM</i>	not relevant
<i>LICENSES</i>	if altimeter used, altimeter license is required
<i>LICENSES</i>	Dittel/TQ KRT-2 license

D.8 ACD-57 and VT-01 Transponder

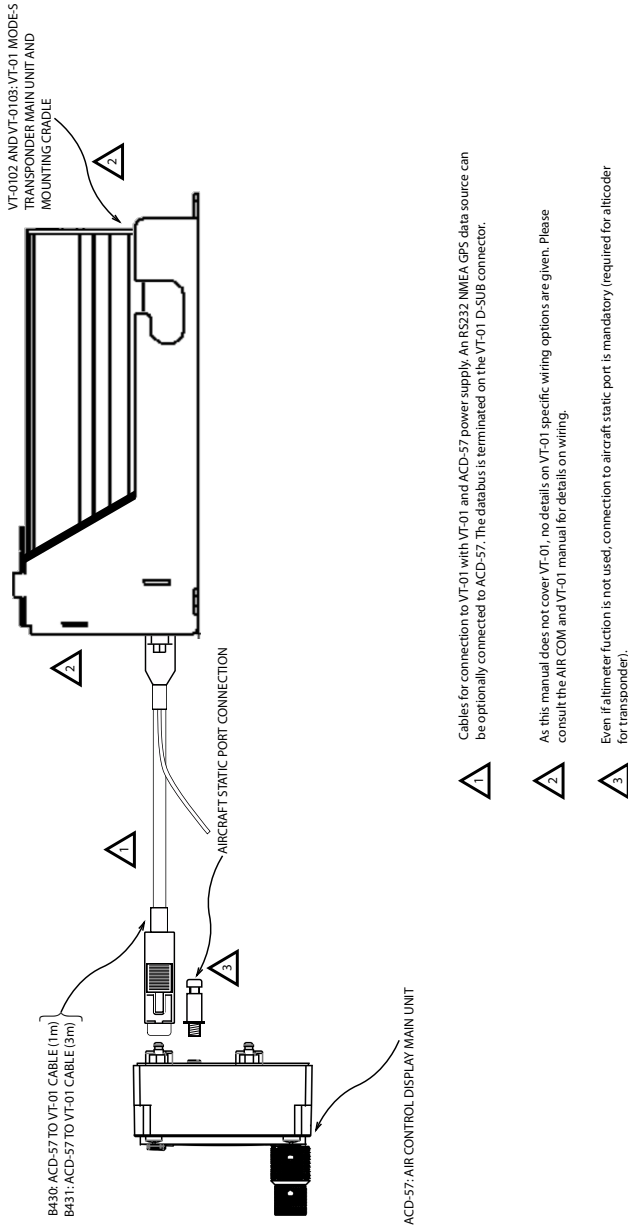

Figure D.11.: ACD-57 and VT-01 Mode-S transponder connected with cable

Configuration parameters recommended for ACD-57 and VT-01 transponder:

<i>Parameter</i>	<i>Recommended Value</i>
<i>DEVICE → INSTALLATION → SOUNDER VOLUME</i>	as required
<i>DEVICE → INSTALLATION → ILLUMINATION</i>	as required
<i>DEVICE → INSTALLATION → POWER ON MODE</i>	as required
<i>DEVICE → INSTALLATION → DATA PORTS → GPS SOURCE</i>	not relevant
<i>DEVICE → INSTALLATION → DATA PORTS → SHARE GPS DATA</i>	not relevant
<i>DEVICE → INSTALLATION → DATA PORTS → DATA BUS NODE ID</i>	100
<i>ALTIMETER → UNITS</i>	as required
<i>ALTIMETER → INSTALLATION → ALT DISPLAY</i>	as required, if altimeter is used, set to ON
<i>ALTIMETER → INSTALLATION → BARO SOURCE</i>	STATIC PORT
<i>ALTIMETER → INSTALLATION → SHARE ALTITUDE</i>	ON
<i>COM CONTROL → CHN SPACING</i>	not relevant
<i>COM CONTROL → STATION NAMES</i>	not relevant
<i>COM CONTROL → KNOB USE</i>	not relevant
<i>COM CONTROL → INSTALLATION → COM DISPLAY</i>	OFF
<i>COM CONTROL → INSTALLATION → COM TYPE</i>	not relevant
<i>COM CONTROL → INSTALLATION → COM SOURCE</i>	not relevant
<i>COM CONTROL → INSTALLATION → COM SYSTEM</i>	not relevant
<i>XPDR CONTROL → VFR PRESET</i>	as required
<i>XPDR CONTROL → INSTALLATION → XPDR DISPLAY</i>	ON
<i>XPDR CONTROL → INSTALLATION → XPDR TYPE</i>	VT01
<i>XPDR CONTROL → INSTALLATION → XPDR SOURCE</i>	PORT 1
<i>XPDR CONTROL → INSTALLATION → XPDR SYSTEM</i>	as required
<i>LICENSES</i>	if altimeter used, altimeter license is required

For the VT-01 Ultracompact, make sure to also follow the instructions in section “Compatible MODE-S Transponders” on page 20.

D.9 Dual ACD-57 and VT-01 Transponder

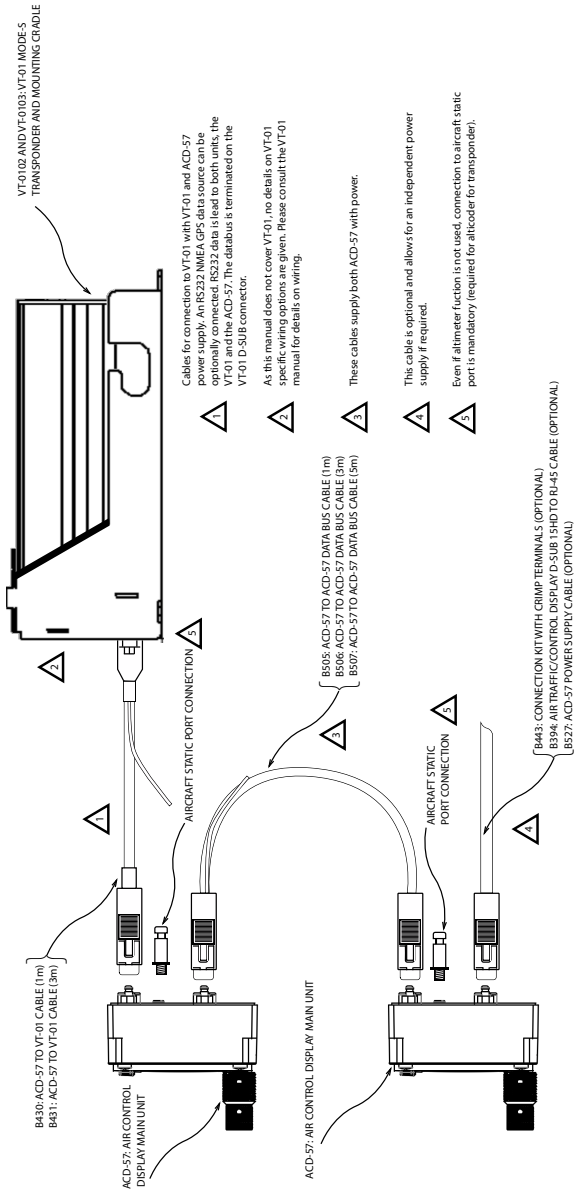

Figure D.12.: Dual ACD-57 and VT-01 Mode-S transponder

Parameters for first ACD-57 (the left/upper one in the diagram with the VT-01 transponder connected):

<i>Parameter</i>	<i>Recommended Value</i>
<i>DEVICE → INSTALLATION → SOUNDER VOLUME</i>	as required
<i>DEVICE → INSTALLATION → ILLUMINATION</i>	as required
<i>DEVICE → INSTALLATION → POWER ON MODE</i>	as required
<i>DEVICE → INSTALLATION → DATA PORTS → GPS SOURCE</i>	as required, if GPS is connected to upper port, set to RS-232 1
<i>DEVICE → INSTALLATION → DATA PORTS → SHARE GPS DATA</i>	as required, if GPS is used, set to ON
<i>DEVICE → INSTALLATION → DATA PORTS → DATA BUS NODE ID</i>	100
<i>ALTIMETER → UNITS</i>	as required
<i>ALTIMETER → INSTALLATION → ALT DISPLAY</i>	as required, if altimeter is used, set to ON
<i>ALTIMETER → INSTALLATION → BARO SOURCE</i>	STATIC PORT
<i>ALTIMETER → INSTALLATION → SHARE ALTITUDE</i>	ON
<i>COM CONTROL → CHN SPACING</i>	not relevant
<i>COM CONTROL → STATION NAMES</i>	not relevant
<i>COM CONTROL → KNOB USE</i>	not relevant
<i>COM CONTROL → INSTALLATION → COM DISPLAY</i>	OFF
<i>COM CONTROL → INSTALLATION → COM TYPE</i>	not relevant
<i>COM CONTROL → INSTALLATION → COM SOURCE</i>	not relevant
<i>COM SYSTEM</i>	not relevant
<i>XPDR CONTROL → VFR PRESET</i>	not relevant
<i>XPDR CONTROL → INSTALLATION → XPDR DISPLAY</i>	ON
<i>XPDR CONTROL → INSTALLATION → XPDR TYPE</i>	VT01
<i>XPDR CONTROL → INSTALLATION → XPDR SOURCE</i>	PORT 1
<i>XPDR SYSTEM</i>	as required
<i>LICENSES</i>	if altimeter used, altimeter license is required

For the VT-01 Ultracompact, make sure to also follow the instructions in section “Compatible MODE-S Transponders” on page 20.

Parameters for second ACD-57 (the right/lower one in the diagram):

<i>Parameter</i>	<i>Recommended Value</i>
<i>DEVICE → INSTALLATION → SOUNDER VOLUME</i>	as required
<i>DEVICE → INSTALLATION → ILLUMINATION</i>	as required
<i>DEVICE → INSTALLATION → POWER ON MODE</i>	as required
<i>DEVICE → INSTALLATION → DATA PORTS → GPS SOURCE</i>	as required, if GPS is connected to other ACD-57 (above), set to DATA BUS
<i>DEVICE → INSTALLATION → DATA PORTS → SHARE GPS DATA</i>	OFF
<i>DEVICE → INSTALLATION → DATA PORTS → DATA BUS NODE ID</i>	101
<i>ALTIMETER → UNITS</i>	as required
<i>ALTIMETER → INSTALLATION → ALT DISPLAY</i>	as required, if altimeter is used, set to ON
<i>ALTIMETER → INSTALLATION → BARO SOURCE</i>	as required, if altimeter is used, set to STATIC PORT
<i>ALTIMETER → INSTALLATION → SHARE ALTITUDE</i>	OFF
<i>COM CONTROL → CHN SPACING</i>	not relevant
<i>COM CONTROL → STATION NAMES</i>	not relevant
<i>COM CONTROL → KNOB USE</i>	not relevant
<i>COM CONTROL → INSTALLATION → COM DISPLAY</i>	OFF
<i>COM CONTROL → INSTALLATION → COM TYPE</i>	not relevant
<i>COM CONTROL → INSTALLATION → COM SOURCE</i>	not relevant
<i>COM SYSTEM</i>	not relevant
<i>XPDR CONTROL → VFR PRESET</i>	as required
<i>XPDR CONTROL → INSTALLATION → XPDR DISPLAY</i>	ON
<i>XPDR CONTROL → INSTALLATION → XPDR TYPE</i>	VT01
<i>XPDR CONTROL → INSTALLATION → XPDR SOURCE</i>	DATA BUS
<i>XPDR SYSTEM</i>	as required
<i>LICENSES</i>	if altimeter used, altimeter license is required

D.10 ACD-57, AIR COM, and VT-01 Transponder

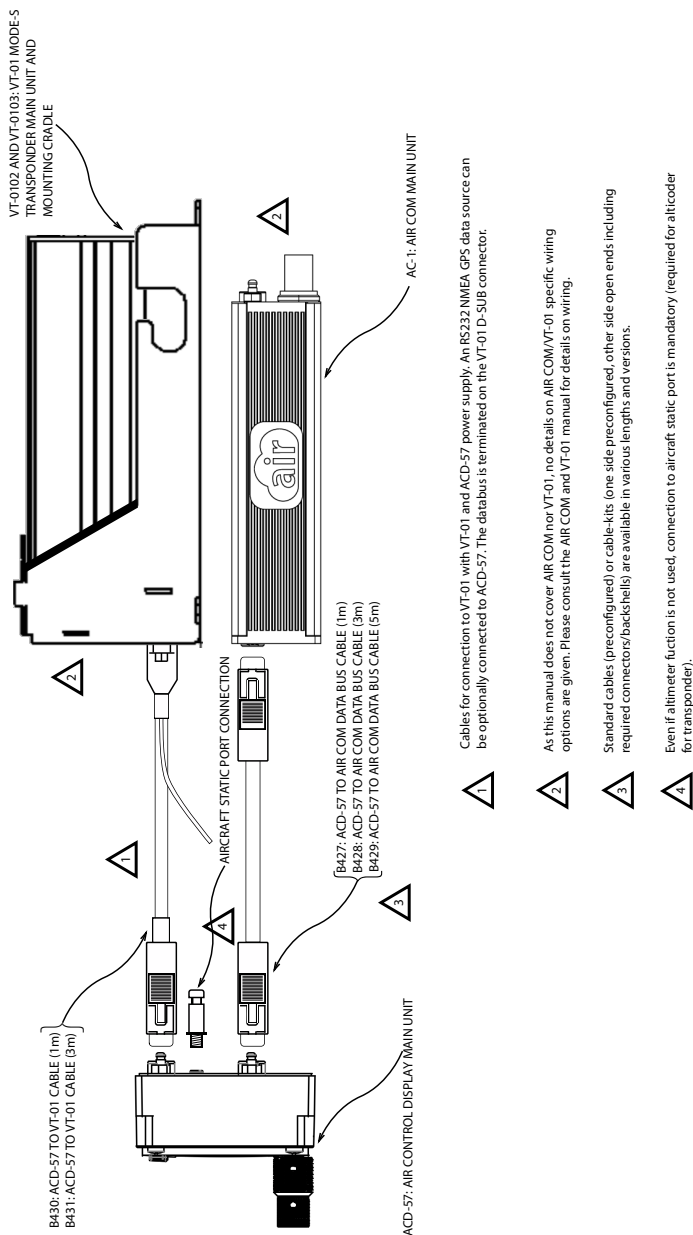

Figure D.13.: ACD-57, AIR COM, and VT-01 Mode-S transponder

Parameters for ACD-57 with VT-01 transponder and AIR COM VHF transceiver connected:

<i>Parameter</i>	<i>Recommended Value</i>
<i>DEVICE → INSTALLATION → SOUNDER VOLUME</i>	as required
<i>DEVICE → INSTALLATION → ILLUMINATION</i>	as required
<i>DEVICE → INSTALLATION → POWER ON MODE</i>	as required
<i>DEVICE → INSTALLATION → DATA PORTS → GPS SOURCE</i>	as required, if GPS is connected to upper port, set to RS-232 1
<i>DEVICE → INSTALLATION → DATA PORTS → SHARE GPS DATA</i>	OFF
<i>DEVICE → INSTALLATION → DATA PORTS → DATA BUS NODE ID</i>	100
<i>ALTIMETER → UNITS</i>	as required
<i>ALTIMETER → INSTALLATION → ALT DISPLAY</i>	as required, if altimeter is used, set to ON
<i>ALTIMETER → INSTALLATION → BARO SOURCE</i>	as required, if altimeter is used, set to STATIC PORT
<i>ALTIMETER → INSTALLATION → SHARE ALTITUDE</i>	OFF
<i>COM CONTROL → CHN SPACING</i>	as required
<i>COM CONTROL → STATION NAMES</i>	as required
<i>COM CONTROL → KNOB USE</i>	as required
<i>COM CONTROL → INSTALLATION → COM DISPLAY</i>	ON
<i>COM CONTROL → INSTALLATION → COM TYPE</i>	AIR COM
<i>COM CONTROL → INSTALLATION → COM SOURCE</i>	PORT 2
<i>COM SYSTEM</i>	as required
<i>XPDR CONTROL → VFR PRESET</i>	as required
<i>XPDR CONTROL → INSTALLATION → XPDR DISPLAY</i>	ON
<i>XPDR CONTROL → INSTALLATION → XPDR TYPE</i>	VT01
<i>XPDR CONTROL → INSTALLATION → XPDR SOURCE</i>	PORT 1
<i>XPDR SYSTEM</i>	as required
<i>LICENSES</i>	if altimeter used, altimeter license is required

For the VT-01 Ultracompact, make sure to also follow the instructions in section “Compatible MODE-S Transponders” on page 20.

D.11 Dual ACD-57, AIR COM, and VT-01 Transponder

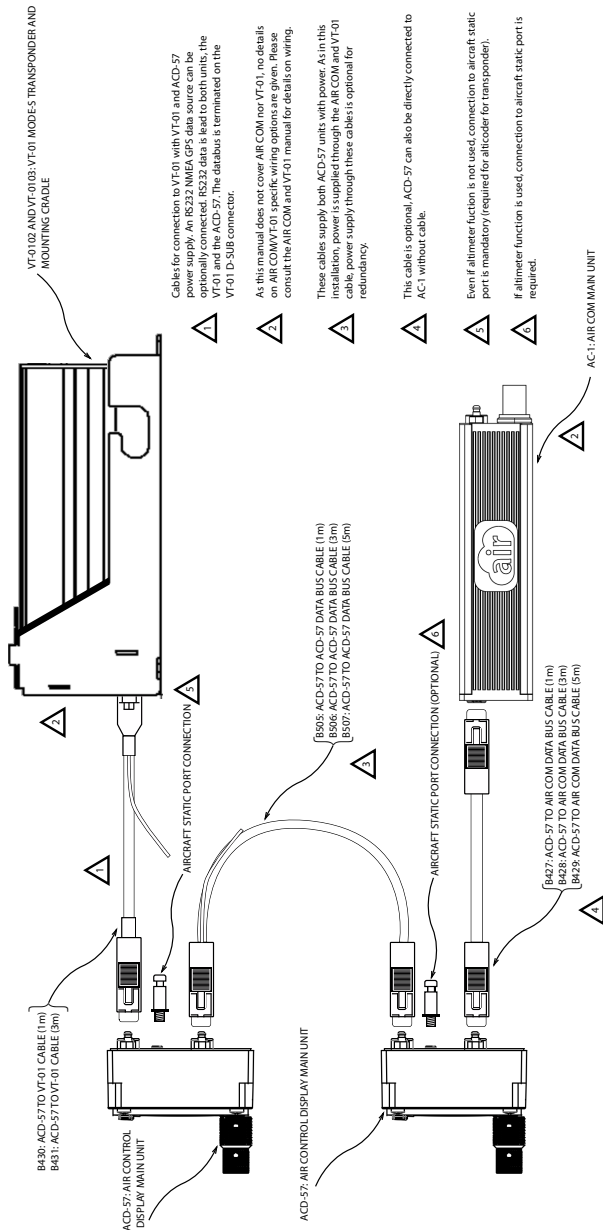

Figure D.14.: Dual ACD-57, AIR COM, and VT-01 Mode-S transponder

Parameters for first ACD-57 (the left/upper one in the diagram with the VT-01 transponder connected):

<i>Parameter</i>	<i>Recommended Value</i>
<i>DEVICE → INSTALLATION → SOUNDER VOLUME</i>	as required
<i>DEVICE → INSTALLATION → ILLUMINATION</i>	as required
<i>DEVICE → INSTALLATION → POWER ON MODE</i>	as required
<i>DEVICE → INSTALLATION → DATA PORTS → GPS SOURCE</i>	as required, if GPS is connected to upper port, set to RS-232 1
<i>DEVICE → INSTALLATION → DATA PORTS → SHARE GPS DATA</i>	as required, if GPS is used, set to ON
<i>DEVICE → INSTALLATION → DATA PORTS → DATA BUS NODE ID</i>	100
<i>ALTIMETER → UNITS</i>	as required
<i>ALTIMETER → INSTALLATION → ALT DISPLAY</i>	as required, if altimeter is used, set to ON
<i>ALTIMETER → INSTALLATION → BARO SOURCE</i>	STATIC PORT
<i>ALTIMETER → INSTALLATION → SHARE ALTITUDE</i>	ON
<i>COM CONTROL → CHN SPACING</i>	as required
<i>COM CONTROL → STATION NAMES</i>	as required
<i>COM CONTROL → KNOB USE</i>	as required
<i>COM CONTROL → INSTALLATION → COM DISPLAY</i>	ON
<i>COM CONTROL → INSTALLATION → COM TYPE</i>	AIR COM
<i>COM CONTROL → INSTALLATION → COM SOURCE</i>	DATA BUS
<i>COM SYSTEM</i>	as required
<i>XPDR CONTROL → VFR PRESET</i>	as required
<i>XPDR CONTROL → INSTALLATION → XPDR DISPLAY</i>	ON
<i>XPDR CONTROL → INSTALLATION → XPDR TYPE</i>	VT01
<i>XPDR CONTROL → INSTALLATION → XPDR SOURCE</i>	PORT 1
<i>XPDR SYSTEM</i>	as required
<i>LICENSES</i>	if altimeter used, altimeter license is required

For the VT-01 Ultracompact, make sure to also follow the instructions in section “Compatible MODE-S Transponders” on page 20.

Parameters for second ACD-57 (the right/lower one in the diagram with the connected AIR COM):

<i>Parameter</i>	<i>Recommended Value</i>
<i>DEVICE → INSTALLATION → SOUNDER VOLUME</i>	as required
<i>DEVICE → INSTALLATION → ILLUMINATION</i>	as required
<i>DEVICE → INSTALLATION → POWER ON MODE</i>	as required
<i>DEVICE → INSTALLATION → DATA PORTS → GPS SOURCE</i>	as required, if GPS is connected to other ACD-57 (above), set to DATA BUS
<i>DEVICE → INSTALLATION → DATA PORTS → SHARE GPS DATA</i>	OFF
<i>DEVICE → INSTALLATION → DATA PORTS → DATA BUS NODE ID</i>	101
<i>ALTIMETER → UNITS</i>	as required
<i>ALTIMETER → INSTALLATION → ALT DISPLAY</i>	as required, if altimeter is used, set to ON
<i>ALTIMETER → INSTALLATION → BARO SOURCE</i>	as required, if altimeter is used, set to STATIC PORT
<i>ALTIMETER → INSTALLATION → SHARE ALTITUDE</i>	OFF
<i>COM CONTROL → CHN SPACING</i>	as required
<i>COM CONTROL → STATION NAMES</i>	as required
<i>COM CONTROL → KNOB USE</i>	as required
<i>COM CONTROL → INSTALLATION → COM DISPLAY</i>	ON
<i>COM CONTROL → INSTALLATION → COM TYPE</i>	AIR COM
<i>COM CONTROL → INSTALLATION → COM SOURCE</i>	PORT 2
<i>COM SYSTEM</i>	as required
<i>XPDR CONTROL → VFR PRESET</i>	as required
<i>XPDR CONTROL → INSTALLATION → XPDR DISPLAY</i>	ON
<i>XPDR CONTROL → INSTALLATION → XPDR TYPE</i>	VT01
<i>XPDR CONTROL → INSTALLATION → XPDR SOURCE</i>	DATA BUS
<i>XPDR SYSTEM</i>	as required
<i>LICENSES</i>	if altimeter used, altimeter license is required

D.12 ACD-57, Becker/TRIG radio, and VT-01 Transponder

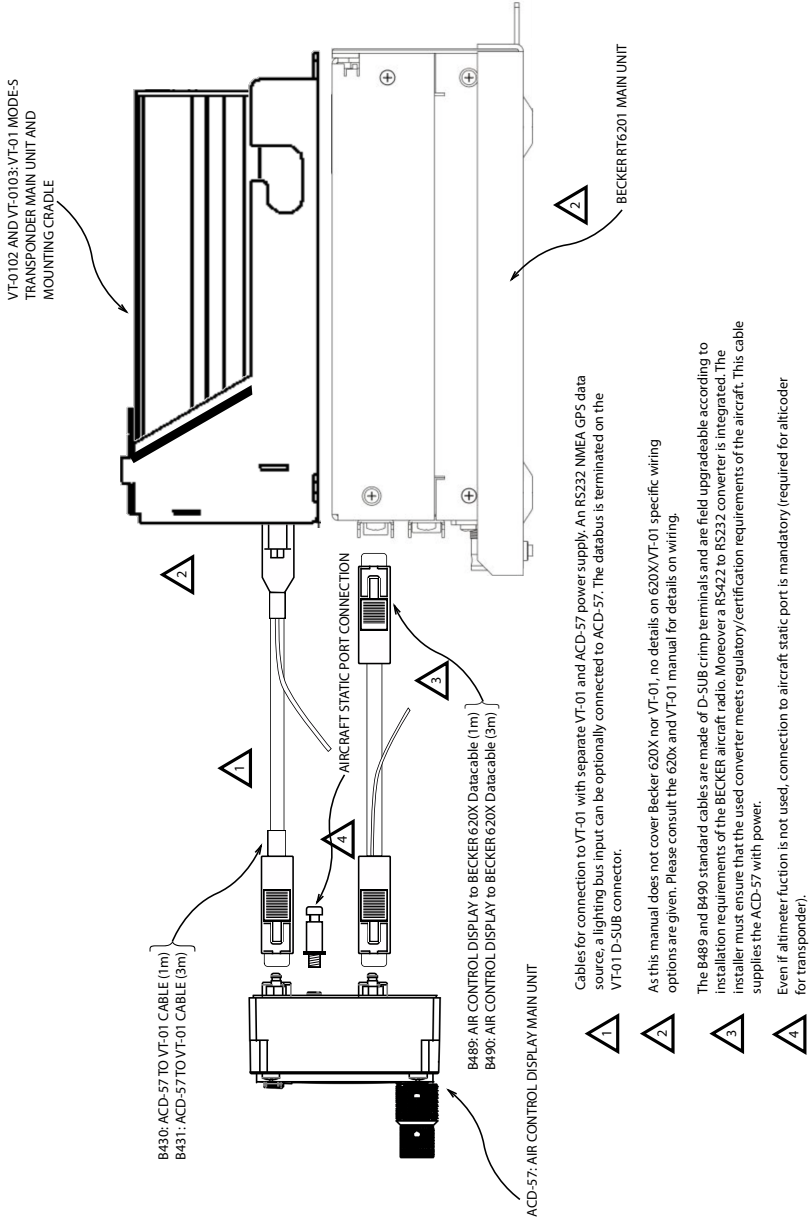

Figure D.15.: ACD-57, Becker 620X, and VT-01 Mode-S transponder

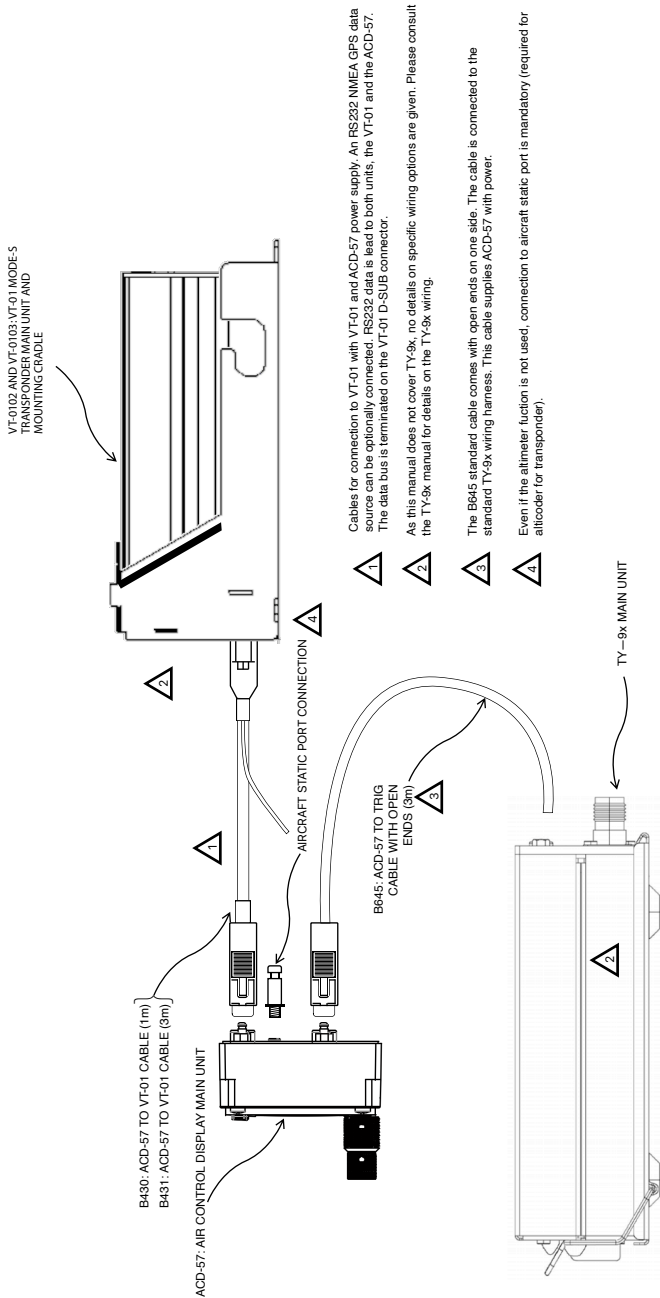

Figure D.16.: ACD-57, TRIG TY91/92, and VT-01 Mode-S transponder

Parameters for ACD-57 with VT-01 transponder and Becker 620X or TRIG TY91/92 VHF transceiver connected:

<i>Parameter</i>	<i>Recommended Value</i>
<i>DEVICE → INSTALLATION → SOUNDER VOLUME</i>	as required
<i>DEVICE → INSTALLATION → ILLUMINATION</i>	as required
<i>DEVICE → INSTALLATION → POWER ON MODE</i>	as required
<i>DEVICE → INSTALLATION → DATA PORTS → GPS SOURCE</i>	as required, if GPS is connected to upper port, set to RS-232 1
<i>DEVICE → INSTALLATION → DATA PORTS → SHARE GPS DATA</i>	OFF
<i>DEVICE → INSTALLATION → DATA PORTS → DATA BUS NODE ID</i>	100
<i>ALTIMETER → UNITS</i>	as required
<i>ALTIMETER → INSTALLATION → ALT DISPLAY</i>	as required, if altimeter is used, set to ON
<i>ALTIMETER → INSTALLATION → BARO SOURCE</i>	as required, if altimeter is used, set to STATIC PORT
<i>ALTIMETER → INSTALLATION → SHARE ALTITUDE</i>	OFF
<i>COM CONTROL → CHN SPACING</i>	as required
<i>COM CONTROL → STATION NAMES</i>	as required
<i>COM CONTROL → KNOB USE</i>	as required
<i>COM CONTROL → INSTALLATION → COM DISPLAY</i>	ON
<i>COM CONTROL → INSTALLATION → COM TYPE</i>	BECKER or TRIG TY
<i>COM CONTROL → INSTALLATION → COM SOURCE</i>	PORT 2
<i>COM SYSTEM</i>	as required
<i>XPDR CONTROL → VFR PRESET</i>	as required
<i>XPDR CONTROL → INSTALLATION → XPDR DISPLAY</i>	ON
<i>XPDR CONTROL → INSTALLATION → XPDR TYPE</i>	VT01
<i>XPDR CONTROL → INSTALLATION → XPDR SOURCE</i>	PORT 1
<i>XPDR SYSTEM</i>	as required
<i>LICENSES</i>	if altimeter used, altimeter license is required
<i>LICENSES</i>	Becker or TRIG license

For the VT-01 Ultracompact, make sure to also follow the instructions in section “Compatible MODE-S Transponders” on page 20.

D.13 Dual ACD-57, Becker/TRIG radio, and VT-01 Transponder

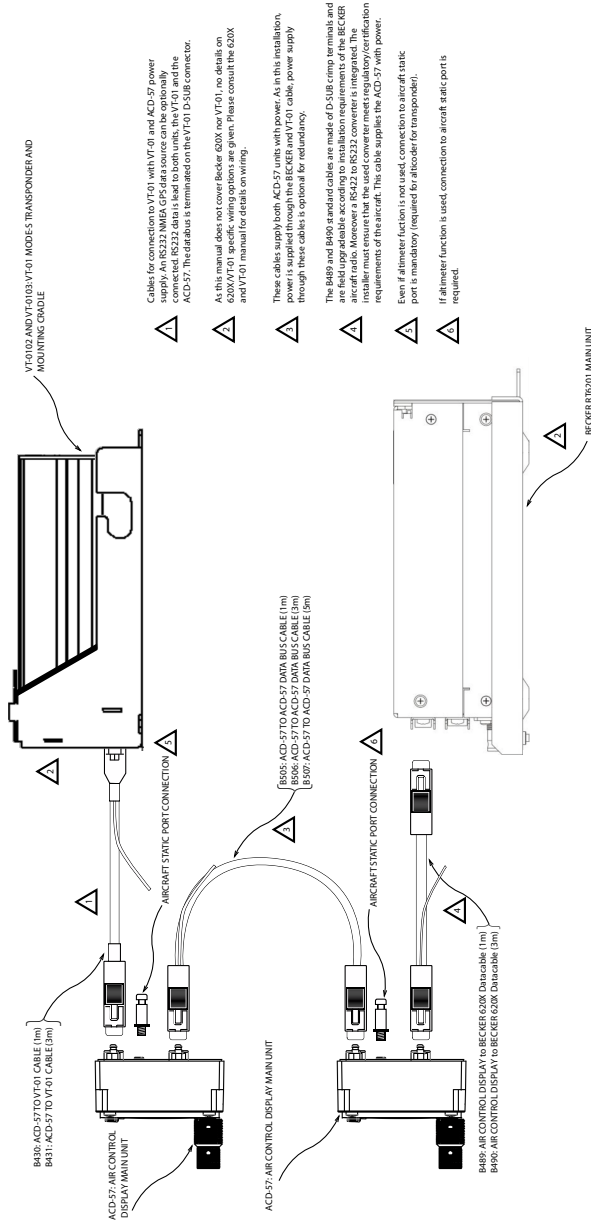

- ▲ Cables for connections to VT-01 and VT-0103 must be connected to the ACD-57 power supply. An RS232 NMEA GPS data source can be optionally connected. RS232 data is lead to both units, the VT-01 and the ACD-57. The data bus is terminated on the VT-01 D-SubB connector.
- ▲ As this manual does not cover Becker 620X nor VT-01, no details on their installation are given. Please consult the 620X and VT-01 manual for details on wiring.
- ▲ These cables supply both ACD-57 units with power. As in this installation, power is supplied through the BECKER and VT-01 cable, power supply through these cables is optional for redundancy.
- ▲ The B889 and B890 standard cables are made of D-SubB crimp terminals and are not suitable for use with the Becker 620X. The Becker 620X installer must ensure that the used converter meets regulatory/certification requirements of the aircraft. This cable supplies the ACD-57 with power.
- ▲ Even if altimeter function is not used, connection to aircraft static port is mandatory (required for altimeter for transponder).
- ▲ If altimeter function is used, connection to aircraft static port is required.

Figure D.17.: Dual ACD-57, Becker 620X, and VT-01 Mode-S transponder

Parameters for first ACD-57 (the left/upper one in the diagram with the VT-01 transponder connected):

<i>Parameter</i>	<i>Recommended Value</i>
<i>DEVICE → INSTALLATION → SOUNDER VOLUME</i>	as required
<i>DEVICE → INSTALLATION → ILLUMINATION</i>	as required
<i>DEVICE → INSTALLATION → POWER ON MODE</i>	as required
<i>DEVICE → INSTALLATION → DATA PORTS → GPS SOURCE</i>	as required, if GPS is connected to upper port, set to RS-232 1
<i>DEVICE → INSTALLATION → DATA PORTS → SHARE GPS DATA</i>	as required, if GPS is used, set to ON
<i>DEVICE → INSTALLATION → DATA PORTS → DATA BUS NODE ID</i>	100
<i>ALTIMETER → UNITS</i>	as required
<i>ALTIMETER → INSTALLATION → ALT DISPLAY</i>	as required, if altimeter is used, set to ON
<i>ALTIMETER → INSTALLATION → BARO SOURCE</i>	STATIC PORT
<i>ALTIMETER → INSTALLATION → SHARE ALTITUDE</i>	ON
<i>COM CONTROL → CHN SPACING</i>	as required
<i>COM CONTROL → STATION NAMES</i>	as required
<i>COM CONTROL → KNOB USE</i>	as required
<i>COM CONTROL → INSTALLATION → COM DISPLAY</i>	ON
<i>COM CONTROL → INSTALLATION → COM TYPE</i>	BECKER or TRIG
<i>COM CONTROL → INSTALLATION → COM SOURCE</i>	DATA BUS
<i>(COM SYSTEM not available)</i>	(not available)
<i>XPDR CONTROL → VFR PRESET</i>	as required
<i>XPDR CONTROL → INSTALLATION → XPDR DISPLAY</i>	ON
<i>XPDR CONTROL → INSTALLATION → XPDR TYPE</i>	VT01
<i>XPDR CONTROL → INSTALLATION → XPDR SOURCE</i>	PORT 1
<i>XPDR SYSTEM</i>	as required
<i>LICENSES</i>	if altimeter used, altimeter license is required

For the VT-01 Ultracompact, make sure to also follow the instructions in section “Compatible MODE-S Transponders” on page 20.

Parameters for second ACD-57 (the right/lower one in the diagram with the connected Becker 620X):

<i>Parameter</i>	<i>Recommended Value</i>
<i>DEVICE → INSTALLATION → SOUNDER VOLUME</i>	as required
<i>DEVICE → INSTALLATION → ILLUMINATION</i>	as required
<i>DEVICE → INSTALLATION → POWER ON MODE</i>	as required
<i>DEVICE → INSTALLATION → DATA PORTS → GPS SOURCE</i>	as required, if GPS is connected to other ACD-57 (above), set to DATA BUS
<i>DEVICE → INSTALLATION → DATA PORTS → SHARE GPS DATA</i>	OFF
<i>DEVICE → INSTALLATION → DATA PORTS → DATA BUS NODE ID</i>	101
<i>ALTIMETER → UNITS</i>	as required
<i>ALTIMETER → INSTALLATION → ALT DISPLAY</i>	as required, if altimeter is used, set to ON
<i>ALTIMETER → INSTALLATION → BARO SOURCE</i>	as required, if altimeter is used, set to STATIC PORT
<i>ALTIMETER → INSTALLATION → SHARE ALTITUDE</i>	OFF
<i>COM CONTROL → CHN SPACING</i>	as required
<i>COM CONTROL → STATION NAMES</i>	as required
<i>COM CONTROL → KNOB USE</i>	as required
<i>COM CONTROL → INSTALLATION → COM DISPLAY</i>	ON
<i>COM CONTROL → INSTALLATION → COM TYPE</i>	BECKER or TRIG
<i>COM CONTROL → INSTALLATION → COM SOURCE</i>	PORT 2
<i>COM SYSTEM</i>	as required
<i>XPDR CONTROL → VFR PRESET</i>	as required
<i>XPDR CONTROL → INSTALLATION → XPDR DISPLAY</i>	ON
<i>XPDR CONTROL → INSTALLATION → XPDR TYPE</i>	VT01
<i>XPDR CONTROL → INSTALLATION → XPDR SOURCE</i>	DATA BUS
<i>XPDR SYSTEM</i>	as required
<i>LICENSES</i>	if altimeter used, altimeter license is required
<i>LICENSES</i>	Becker or TRIG license

D.14 ACD-57, Dittel/TQ KRT2, and VT-01 Transponder

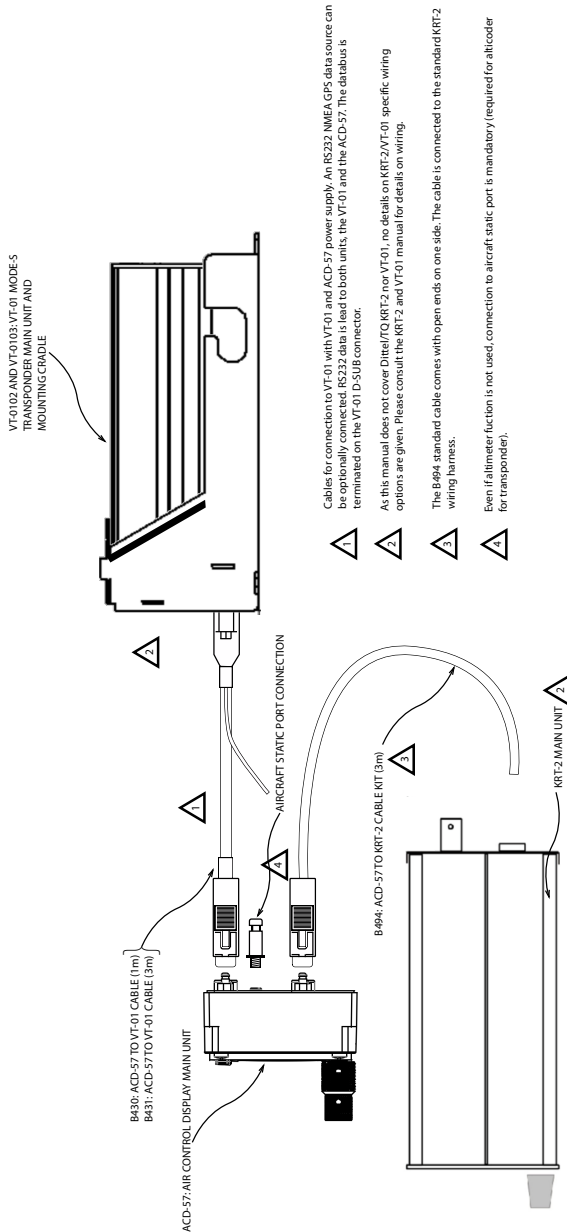

Figure D.19.: ACD-57, Dittel/TQ KRT-2, and VT-01 Mode-S transponder

Parameters for ACD-57 with VT-01 transponder and Dittel/TQ KRT-2 transceiver connected:

<i>Parameter</i>	<i>Recommended Value</i>
<i>DEVICE → INSTALLATION → SOUNDER VOLUME</i>	as required
<i>DEVICE → INSTALLATION → ILLUMINATION</i>	as required
<i>DEVICE → INSTALLATION → POWER ON MODE</i>	as required
<i>DEVICE → INSTALLATION → DATA PORTS → GPS SOURCE</i>	as required, if GPS is connected to upper port, set to RS-232 1
<i>DEVICE → INSTALLATION → DATA PORTS → SHARE GPS DATA</i>	OFF
<i>DEVICE → INSTALLATION → DATA PORTS → DATA BUS NODE ID</i>	100
<i>ALTIMETER → UNITS</i>	as required
<i>ALTIMETER → INSTALLATION → ALT DISPLAY</i>	as required, if altimeter is used, set to ON
<i>ALTIMETER → INSTALLATION → BARO SOURCE</i>	as required, if altimeter is used, set to STATIC PORT
<i>ALTIMETER → INSTALLATION → SHARE ALTITUDE</i>	OFF
<i>COM CONTROL → CHN SPACING</i>	as required
<i>COM CONTROL → STATION NAMES</i>	as required
<i>COM CONTROL → KNOB USE</i>	as required
<i>COM CONTROL → INSTALLATION → COM DISPLAY</i>	ON
<i>COM CONTROL → INSTALLATION → COM TYPE</i>	KRT2
<i>COM CONTROL → INSTALLATION → COM SOURCE</i>	PORT 2
<i>COM SYSTEM</i>	as required
<i>XPDR CONTROL → VFR PRESET</i>	as required
<i>XPDR CONTROL → INSTALLATION → XPDR DISPLAY</i>	ON
<i>XPDR CONTROL → INSTALLATION → XPDR TYPE</i>	VT01
<i>XPDR CONTROL → INSTALLATION → XPDR SOURCE</i>	PORT 1
<i>XPDR SYSTEM</i>	as required
<i>LICENSES</i>	if altimeter used, altimeter license is required
<i>LICENSES</i>	Dittel/TQ KRT2 license

For the VT-01 Ultracompact, make sure to also follow the instructions in section “Compatible MODE-S Transponders” on page 20.

Parameters for first ACD-57 (the left/upper one in the diagram with the VT-01 transponder connected):

<i>Parameter</i>	<i>Recommended Value</i>
<i>DEVICE → INSTALLATION → SOUNDER VOLUME</i>	as required
<i>DEVICE → INSTALLATION → ILLUMINATION</i>	as required
<i>DEVICE → INSTALLATION → POWER ON MODE</i>	as required
<i>DEVICE → INSTALLATION → DATA PORTS → GPS SOURCE</i>	as required, if GPS is connected to upper port, set to RS-232 1
<i>DEVICE → INSTALLATION → DATA PORTS → SHARE GPS DATA</i>	as required, if GPS is used, set to ON
<i>DEVICE → INSTALLATION → DATA PORTS → DATA BUS NODE ID</i>	100
<i>ALTIMETER → UNITS</i>	as required
<i>ALTIMETER → INSTALLATION → ALT DISPLAY</i>	as required, if altimeter is used, set to ON
<i>ALTIMETER → INSTALLATION → BARO SOURCE</i>	STATIC PORT
<i>ALTIMETER → INSTALLATION → SHARE ALTITUDE</i>	ON
<i>COM CONTROL → CHN SPACING</i>	as required
<i>COM CONTROL → STATION NAMES</i>	as required
<i>COM CONTROL → KNOB USE</i>	as required
<i>COM CONTROL → INSTALLATION → COM DISPLAY</i>	ON
<i>COM CONTROL → INSTALLATION → COM TYPE</i>	KRT2
<i>COM CONTROL → INSTALLATION → COM SOURCE</i>	DATA BUS
<i>(COM SYSTEM not available)</i>	(not available)
<i>XPDR CONTROL → VFR PRESET</i>	as required
<i>XPDR CONTROL → INSTALLATION → XPDR DISPLAY</i>	ON
<i>XPDR CONTROL → INSTALLATION → XPDR TYPE</i>	VT01
<i>XPDR CONTROL → INSTALLATION → XPDR SOURCE</i>	PORT 1
<i>XPDR SYSTEM</i>	as required
<i>LICENSES</i>	if altimeter used, altimeter license is required

For the VT-01 Ultracompact, make sure to also follow the instructions in section “Compatible MODE-S Transponders” on page 20.

Parameters for second ACD-57 (the right/lower one in the diagram with the connected KRT-2):

<i>Parameter</i>	<i>Recommended Value</i>
<i>DEVICE → INSTALLATION → SOUNDER VOLUME</i>	as required
<i>DEVICE → INSTALLATION → ILLUMINATION</i>	as required
<i>DEVICE → INSTALLATION → POWER ON MODE</i>	as required
<i>DEVICE → INSTALLATION → DATA PORTS → GPS SOURCE</i>	as required, if GPS is connected to other ACD-57 (above), set to DATA BUS
<i>DEVICE → INSTALLATION → DATA PORTS → SHARE GPS DATA</i>	OFF
<i>DEVICE → INSTALLATION → DATA PORTS → DATA BUS NODE ID</i>	101
<i>ALTIMETER → UNITS</i>	as required
<i>ALTIMETER → INSTALLATION → ALT DISPLAY</i>	as required, if altimeter is used, set to ON
<i>ALTIMETER → INSTALLATION → BARO SOURCE</i>	as required, if altimeter is used, set to STATIC PORT
<i>ALTIMETER → INSTALLATION → SHARE ALTITUDE</i>	OFF
<i>COM CONTROL → CHN SPACING</i>	as required
<i>COM CONTROL → STATION NAMES</i>	as required
<i>COM CONTROL → KNOB USE</i>	as required
<i>COM CONTROL → INSTALLATION → COM DISPLAY</i>	ON
<i>COM CONTROL → INSTALLATION → COM TYPE</i>	KRT2
<i>COM CONTROL → INSTALLATION → COM SOURCE</i>	PORT 2
<i>COM SYSTEM</i>	as required
<i>XPDR CONTROL → VFR PRESET</i>	as required
<i>XPDR CONTROL → INSTALLATION → XPDR DISPLAY</i>	ON
<i>XPDR CONTROL → INSTALLATION → XPDR TYPE</i>	VT01
<i>XPDR CONTROL → INSTALLATION → XPDR SOURCE</i>	DATA BUS
<i>XPDR SYSTEM</i>	as required
<i>LICENSES</i>	if altimeter used, altimeter license is required
<i>LICENSES</i>	Dittel/TQ KRT2 license

E.2 COM Wiring Diagrams

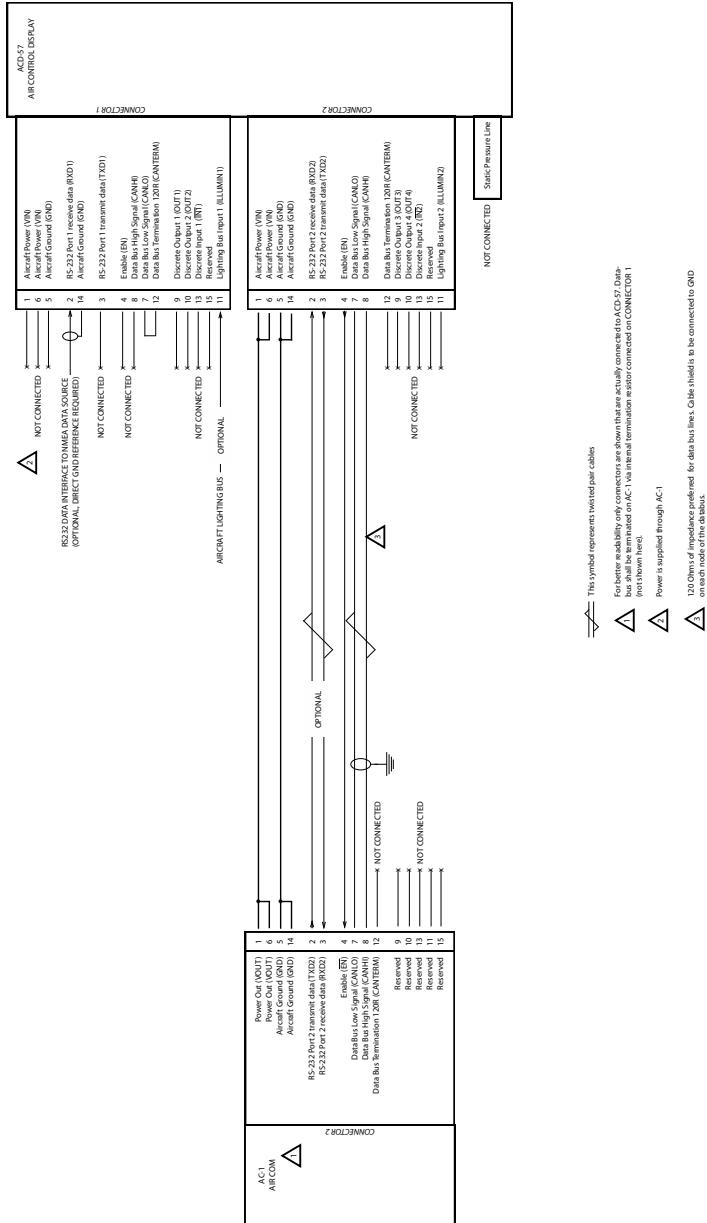

Figure E.2.: Connection to an AIR COM aircraft radio

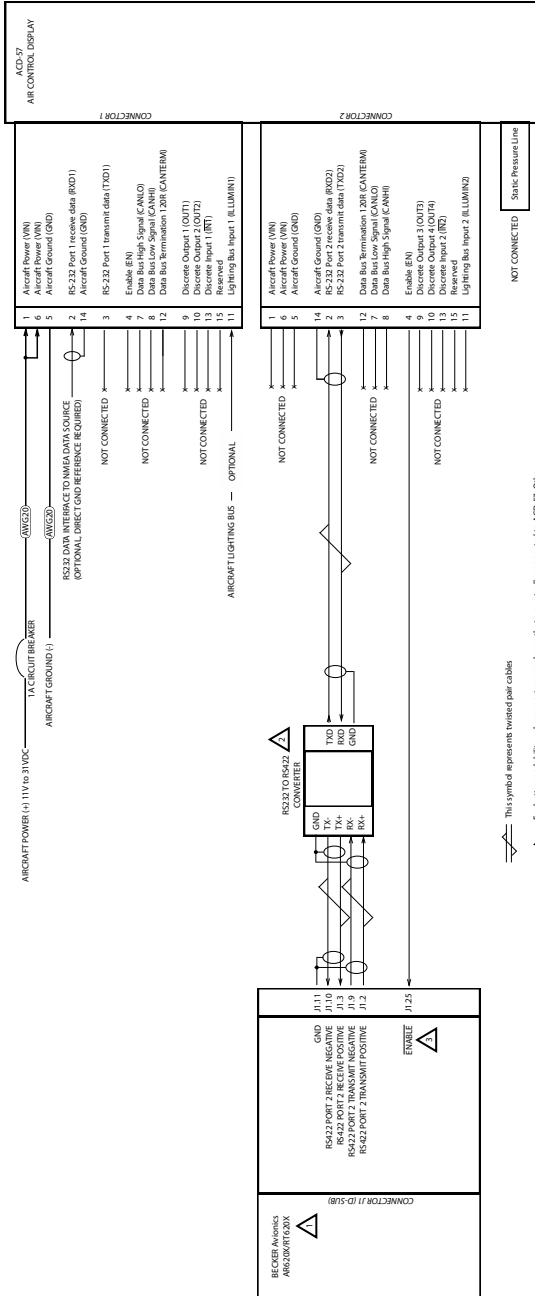

Figure E.3.: Connection to a Becker 620X aircraft radio (third party manufacturer)

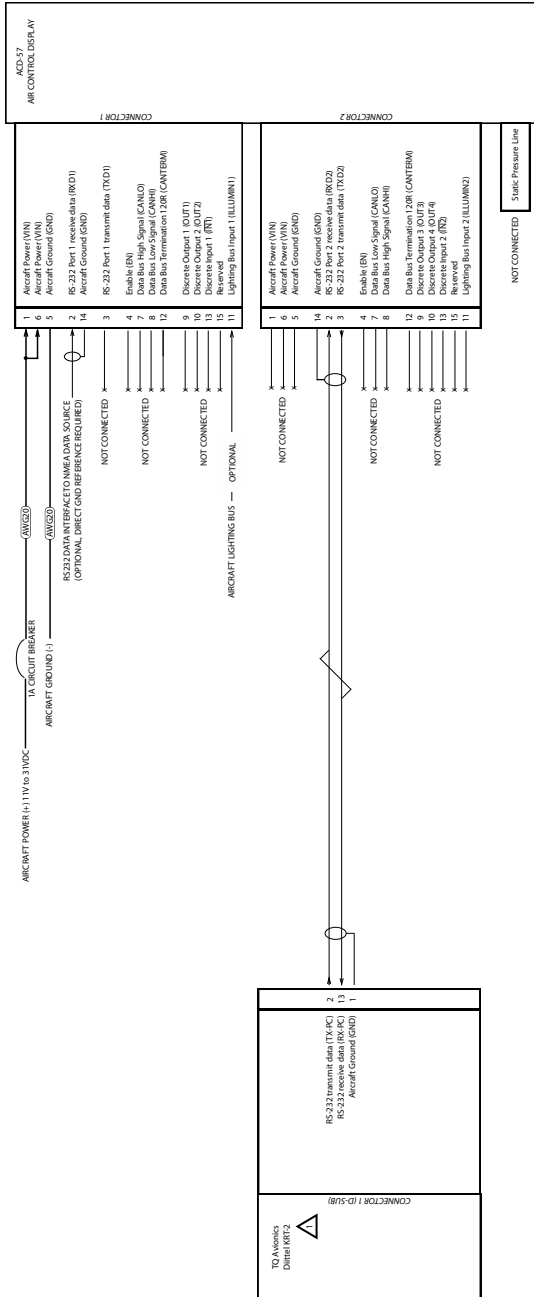

Figure E.5.: Connection to a TQ/Dittel KRT-2 aircraft radio (third party manufacturer)

E.3 Transponder Wiring Diagrams

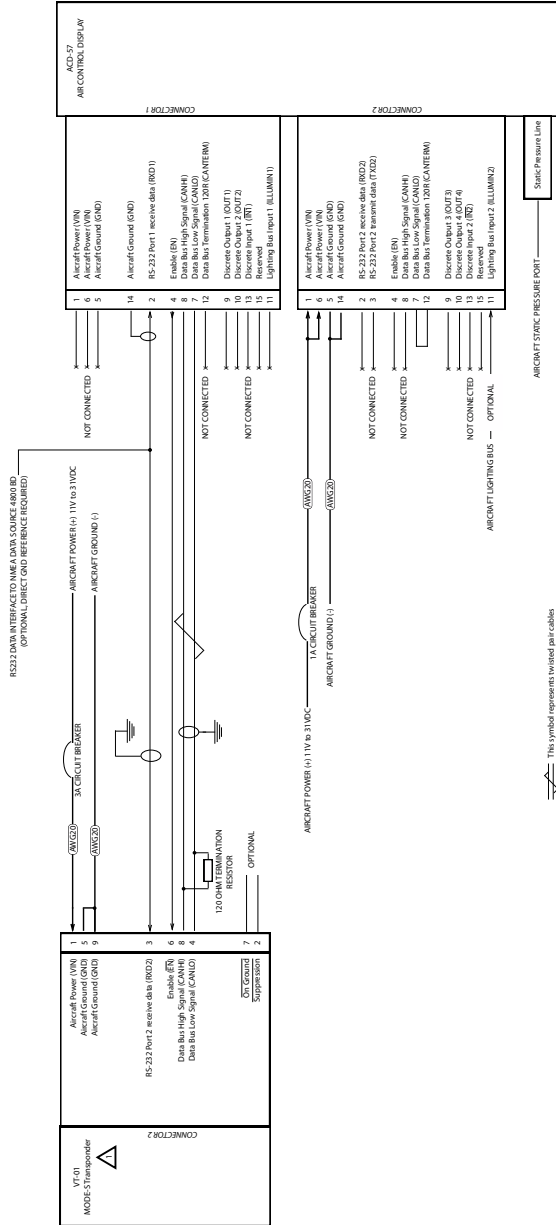

Figure E.6.: Connection to VT-01 Mode-S transponder

E.4 COM and Transponder Wiring Diagrams

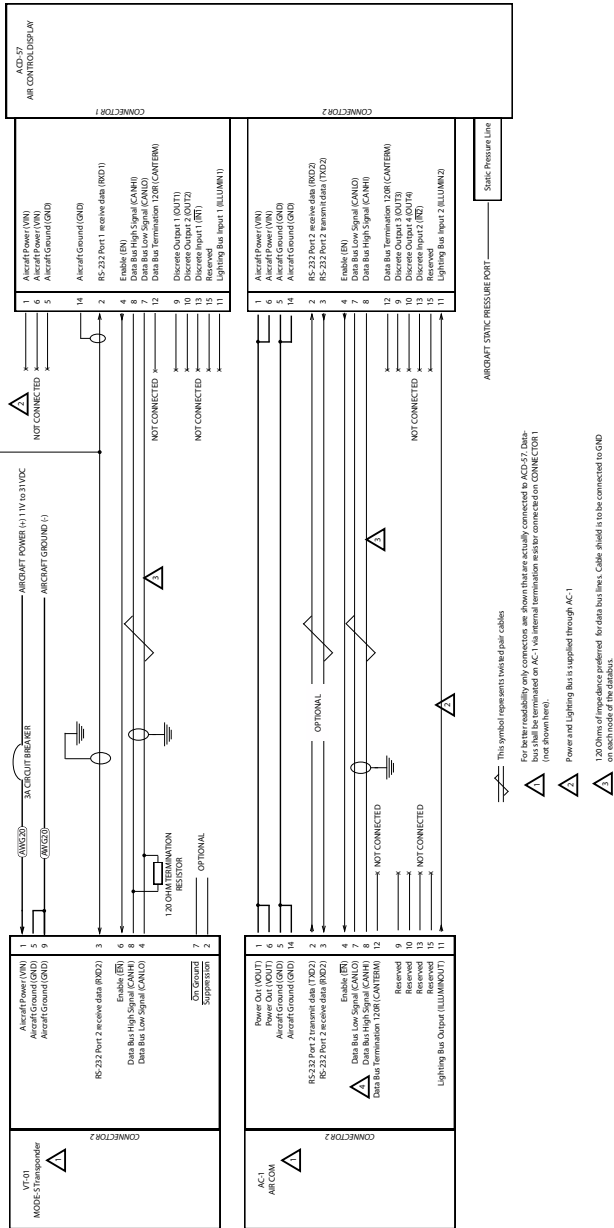

Figure E.7.: Connection to AIR COM aircraft radio and VT-01 Mode-S transponder

F.1 RS-232 Interface

ACD-57 accepts configuration commands from third party devices and transmits status messages via one of its RS-232 interfaces. Usually the same interface is used, which is also used for the serial input protocol for NMEA-0183 data. The data rate can be configured.

F.2 Message Structure

The general message structure, including checksum generation is same as standard NMEA-0183 message structure.

F.3 Multiple Device Support

The sentences, used in this protocol, are used for multiple device types. For better structuring <DeviceCode> fields are used in several sentence types.

A single physical device may support multiple <DeviceCodes> (e.g. an ACD-57 can support ACD, ALT, COM and XPDR).

<i>DeviceCode</i>	<i>Description</i>
ACD	Air Control Display
ALT	Altimeter
COM	COM radio
XPDR	Transponder

F.4 Configuration Sentences

\$PAAVC,<QueryType>,<DeviceCode>,<ConfigurationItem>(<Value>)

F.4.1 Query Types

<i>QueryType</i>	<i>Description</i>
R	Request to send the value of a <ConfigurationItem>; parameter <Value> should be omitted.
S	Request to set <ConfigurationItem> to <Value>.
A	Device answers a request with current (or new) content of <ConfigurationItem>.

F.4.2 Errors

The device returns \$PAAVC,A,ERROR* in case of an unknown or unsupported <DeviceCode>. It returns \$PAAVC,A,<DeviceCode>,ERROR* in case of an error or an unknown or unsupported <ConfigurationItem>.

F.4.3 Device Code

The target device for this configuration item.

F.4.4 ACD Configuration Items

<i>Config Item</i>	<i>Description</i>	<i>Values</i>
SWVER	Software Version	String value.

F.4.5 Altimeter Configuration Items

<i>Config Item</i>	<i>Description</i>	<i>Values</i>
QNH	QNH value in Pa.	Unsigned integer value (e.g. 101325).

These items are only available if the altimeter functions are used on this particular ACD-57.

F.4.6 COM Radio Configuration Items

<i>Config Item</i>	<i>Description</i>	<i>Values</i>
CHN1	Primary radio channel, read-only.	25kHz frequencies and 8.33kHz channels as unsigned integer values between 118000 and 136990.
CHN2	Secondary radio channel.	25kHz frequencies and 8.33kHz channels as unsigned integer values between 118000 and 136990.
RXVOL1	Primary radio channel volume.	Unsigned integer values, 0–100
RXVOL2	Secondary radio channel volume. Dependent on the connected radio type, this may implicitly change the value of Dual Watch Mode.	Unsigned integer values, 0–100
SQL	Squelch Level. Dependent on the connected radio type, this may implicitly change the value of SQLOFF.	Unsigned integer values, 0–100
SQLOFF	Squelch Off. Dependent on the connected radio type, this may implicitly change the value of SQL.	0: squelch on 1: squelch off
ICVOL1	Intercom 1 Volume	Unsigned integer values, 0–100
ICVOX1	Intercom 1 VOX	Unsigned integer values, 0–100
ICVOL2	Intercom 2 Volume	Unsigned integer values, 0–100
ICVOX2	Intercom 2 VOX	Unsigned integer values, 0–100
AUXVOL	Volume gain of aux input	Unsigned integer values, 0–100
DWATCH	Dual watch mode. Dependent on the connected radio type, this may implicitly change the value of RXVOL2.	0: dual watch off 1: dual watch on

These items are only available if a COM radio is connected to the ACD-57. Dependent on the connected radio type, some values may not be available.

F.4.7 Transponder Configuration Items

<i>Config Item</i>	<i>Description</i>	<i>Values</i>
SQUAWK	Squawk code value.	Octal unsigned integer value between 0000 and 7777 (digits 0–7).
ACTIVE	Active flag.	0: standby (transponder is switched off / "SBY" mode) 1: active (transponder is switched on / "ALT" or "ON" mode, dependent of ALTINH)
ALTINH	Altitude inhibit flag.	0: transmit altitude ("ALT" mode if active) 1: do not transmit altitude ("ON" mode if active)

These items are only available if a transponder is connected to the ACD-57.

F.5 Command Sentences

\$PAAVX,<DeviceCode>,<CommandCode>(<Result>)

F.5.1 Device Code

The target device for this command.

F.5.2 Errors

The device returns \$PAAVX,ERROR* in case of an unknown or unsupported <DeviceCode>.

F.5.3 Command Results

<i>Result</i>	<i>Description</i>
OK	Command was processed successfully.
ERROR	Command could not be processed successfully or <CommandCode> is unknown or unsupported.

F.5.4 COM Radio Command Codes

<i>CommandCode</i>	<i>Description</i>
XCHN	Exchange primary and secondary channel.

These items are only available if a COM radio is connected to the ACD-57.

F.5.5 Transponder Command Codes

<i>CommandCode</i>	<i>Description</i>
IDENT	Start SPI (Ident).

These items are only available if a transponder is connected to the ACD-57.

F.6 Status Sentences

\$PAAVS,<DeviceCode>,<Value1>(<Value2>,<Value3>,...)

Status sentences are sent every 2 seconds, or immediately if a value has changed.

F.6.1 Device Codes

The source device for this status sentence.

F.6.2 Altimeter Status

\$PAAVS,ALT,<ALTQNE>,<ALTQNH>,<QNH>

Field	Description	Values
ALTQNE	Current QNE altitude in meters.	Decimal number with two decimal places.
ALTQNH	Current QNH altitude in meters.	Decimal number with two decimal places.
QNH	Current QNH setting in pascal.	Unsigned integer values (e.g. 101325).

Fields, for which no data is available (e.g. due to missing functionality or a failure), are left empty.

This sentence is only available if the altimeter functions are used on this particular ACD-57.

F.6.3 COM Radio Status

\$PAAVS,COM,<CHN1>,<CHN2>,<RXVOL1>,<RXVOL2>,<DWATCH>,<RX1>,<RX2>,<TX1>

Field	Description	Values
CHN1	Primary radio channel.	25kHz frequencies and 8.33kHz channels as unsigned integer values between 118000 and 136990.
CHN2	Secondary radio channel.	25kHz frequencies and 8.33kHz channels as unsigned integer values between 118000 and 136990.
RXVOL1	Primary radio channel volume.	Unsigned integer values, 0-100
RXVOL2	Secondary radio channel volume.	Unsigned integer values, 0-100
DWATCH	Dual watch mode.	0: dual watch off 1: dual watch on
RX1	Primary channel rx state.	0: no signal received 1: signal received
RX2	Secondary channel rx state.	0: no signal received 1: signal received
TX1	Transmit active	0: no transmission 1: transmitting signal

Fields, for which no data is available (e.g. due to missing functionality or a failure), are left empty.

e.g.: \$PAAVS,COM,118275,122550,75,,1,1,0,0*1A

This sentence is only available if a radio is connected to the ACD-57.

F.6.4 Transponder Status

\$PAAVS,XPDR,<SQUAWK>,<ACTIVE>,<ALTINH>,<ALT>,<SPI>,<ALLCALLSINH>

<i>Field</i>	<i>Description</i>	<i>Values</i>
SQUAWK	Squawk value	Octal unsigned integer values between 0000 and 7777 (digits 0–7).
ACTIVE	Active flag	0: standby 1: active
ALTINH	Altitude inhibit flag.	0: not set (“ALT”, if active) 1: set (“ON”, if active)
ALT	Transmitted altitude in FL.	Integer value
SPI	Special Position Ident flag.	0: not set 1: set (“IDENT”)
ALLCALLSINH	Allcalls inhibit flag.	0: not set 1: set (“GND Mode”)

Fields, for which no data is available (e.g. due to missing functionality or a failure), are left empty.

This sentence is only available if a transponder is connected to the ACD-57.

F.7 Error Sentences

\$PAAVE,<DeviceCode>,<Severity>,<ErrorCode>(<ErrorMessage>)

F.7.1 Device Codes

The source device for this error sentence.

F.7.2 Severity

<i>Severity</i>	<i>Description</i>
0	No error, information only.
1	Warning, but full functionality available.
2	Functionality reduced.
3	Fatal error, device does not work.

F.7.3 Error Code

Hexadecimal representation of a 32 bit error code.

F.7.4 Error Message

Optional error description.



Checkout Log

G.1 Installation

1. The installation has been performed in accordance with the instructions shown in this manual.
2. Wiring checks have been performed.
3. Connector engagement checks have been performed.

G.2 Ground Checks

1. Interface checks have been performed. / Check not required.
2. Serial Control Interface checks have been performed. / Check not required.
3. COM check has been performed. / Check not required.
4. XPDR check has been performed. / Check not required.
5. Altimeter check has been performed. / Check not required.
6. Lighting, controls, and alert sounder have been checked.
7. Version check has been performed.
8. License check has been performed.

G.3 Interference Checks

1. EMI test and check for interference has been performed.

G.4 Documentation

1. Aircraft documentation updated.
2. All documentation, including this log, the configuration, and the license log has been filled out and stored in a safe place together with other aircraft documents.

I hereby confirm the above mentioned steps have been completed and that no issues, problems or failures have been found.

Name, date, signature _____

H.1 Device

H.1.1 Device Infos

- PID: Product identification: _____
- VID: Vendor identification/manufacturer: _____
- VER: Software version: _____
- BUILD: Software build identification: _____
- SERIAL: Device serial number: _____
- Installed Databases Information (Version/Expiration Date): _____

H.1.2 Sounder Volume

- Sounder Volume: _____

H.1.3 Illumination

- MODE: MANUAL / AUTO / LIGHTING BUS
- Manual INTENSITY: _____
- Minimum INTENSITY: _____
- Maximum INTENSITY: _____
- If LIGHTING BUS selected, LIGHTING BUS source: _____
- If LIGHTING BUS selected, LIGHTING BUS Minimum: _____
- If LIGHTING BUS selected, LIGHTING BUS Maximum: _____

H.1.4 Power On Mode

- POWER ON MODE: ON / OFF

H.1.5 Data Ports

- GPS source: NOT CONNECTED / RS-232 1 / RS-232 2 / DATA BUS
- Share GPS data: ON / OFF
- Data Bus Node ID: _____ (this ACD-57 device is number _____ of a total of _____ ACD-57 devices in this data bus installation)
- Serial Control Interface: NOT CONNECTED / RS-232 1 / RS-232 2
Baud Rate: _____

H.2 Altimeter

H.2.1 Units

- Altitude units: meters / feet
- Pressure units: hPa / inHg

H.2.2 Installation

- Altimeter Display: ON / OFF
- BARO SOURCE: NOT CONNECTED / STATIC PORT / DATA BUS
- SHARE ALTITUDE: ON / OFF

H.3 COM Control Configuration

- CHN SPACING: BOTH / 25kHz / 8.3kHz
- STATION NAMES: ON / OFF
- KNOB USE: VOLUME / CHANNEL
- COM DISPLAY: ON / OFF
- COM TYPE: AIR COM / Becker / KRT2
- COM SOURCE: DATA BUS / RS-232 1 / RS-232 2

H.4 COM System Configuration

Please note configuration data in the specific configuration log form of the connected COM system.

H.5 XPDR Control Configuration

- VFR PRESET: _____
- XPDR DISPLAY: ON / OFF
- COM TYPE: VT01
- COM SOURCE: DATA BUS / PORT1 / PORT2

H.6 XPDR System Configuration

Please note configuration data in the specific configuration log form of the connected XPDR system.

Name, date, signature _____

This log is used for documentation of installed licenses. Installed licenses can be found on the device in *CONFIGURATION MENU* → *LICENSES*.

ACD-57 Serial Number: _____

I.1 Installed Function Licenses

• License Type: _____ Date: _____ Expires: _____

License Code: _____

• License Type: _____ Date: _____ Expires: _____

License Code: _____

• License Type: _____ Date: _____ Expires: _____

License Code: _____

• License Type: _____ Date: _____ Expires: _____

License Code: _____

• License Type: _____ Date: _____ Expires: _____

License Code: _____

It is required that all license codes are carefully noted in this log. If the device is repaired or reset to factory defaults, the code has to be re-entered. Customer license purchase history data is not saved. Therefore, if the code gets lost, the function license has to be purchased again at full cost to restore functionality.